



Owner's Manual



INSTALLERS: PLEASE BE SURE TO LEAVE THIS
MANUAL WITH THE OWNER. THANK YOU!

APPLY S/N
STICKER HERE



LIMITED ONE YEAR WARRANTY ON SCREEN INNOVATIONS PRODUCTS

Screen Innovations warrants its products, to the original purchaser only, to be free from defects in materials and workmanship for a period of one (1) year from the date of purchase by the original purchaser provided they are properly operated according to Screen Innovations' instructions and are not damaged due to improper handling or treatment after shipment from the factory.

This warranty does not apply to equipment showing evidence of misuse, abuse, or accidental damage, or which has been tampered with or repaired by a person other than authorized Screen Innovations personnel.

Screen Innovations' sole obligation under this warranty shall be to repair or to replace (at Screen Innovations' option) the defective part of the merchandise. Returns for service should be made to your Screen Innovations' dealer. If it is necessary for the dealer to return the screen or part to Screen Innovations, transportation expenses to and from Screen Innovations are payable by the purchaser and Screen Innovations is not responsible for damage in shipment. To protect yourself against damage or loss in transit, insure the product and prepay all transportation expenses.

THIS WARRANTY IS IN LIEU OF ALL OTHER WARRANTIES, EXPRESS OR IMPLIED, INCLUDING WARRANTIES AS TO FITNESS FOR USE AND MERCHANT ABILITY. Any implied warranties of fitness for use, or merchantability, that may be mandated by statute or rule of law are limited to the one (1) year warranty period. This warranty gives you specific legal rights, and you may also have other rights, which vary from state-to-state. NO LIABILITY IS ASSUMED FOR EXPENSES OR DAMAGES RESULTING FROM INTERRUPTION IN OPERATION OF EQUIPMENT, OR FOR INCIDENTAL, DIRECT, OR CONSEQUENTIAL DAMAGES OF ANY NATURE.

In the event that there is a defect in materials or workmanship of a Screen Innovations product, you may contact our Sales Partners at 9715-B Burnet Road Suite 400, Austin, TX 78758, (512) 832-6939.

IMPORTANT: THIS WARRANTY SHALL NOT BE VALID AND SCREEN INNOVATIONS SHALL NOT BE BOUND BY THIS WARRANTY IF THE PRODUCT IS NOT OPERATED IN ACCORDANCE WITH SCREEN INNOVATIONS' WRITTEN INSTRUCTIONS.

Keep your sales receipt to prove the date of purchase and your original ownership.

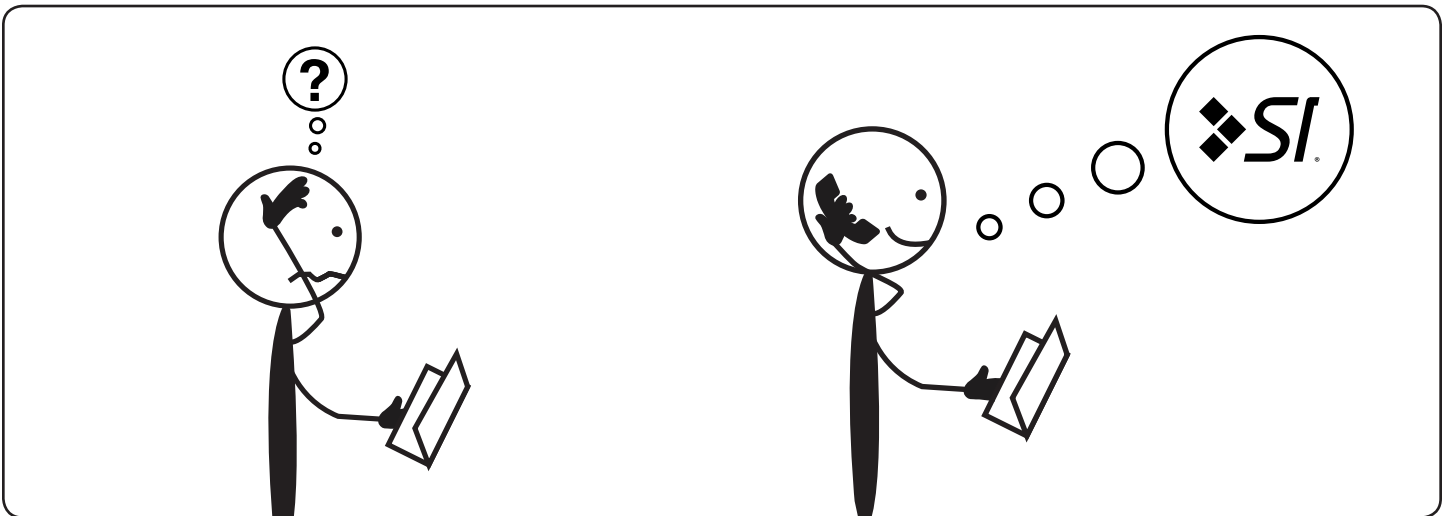
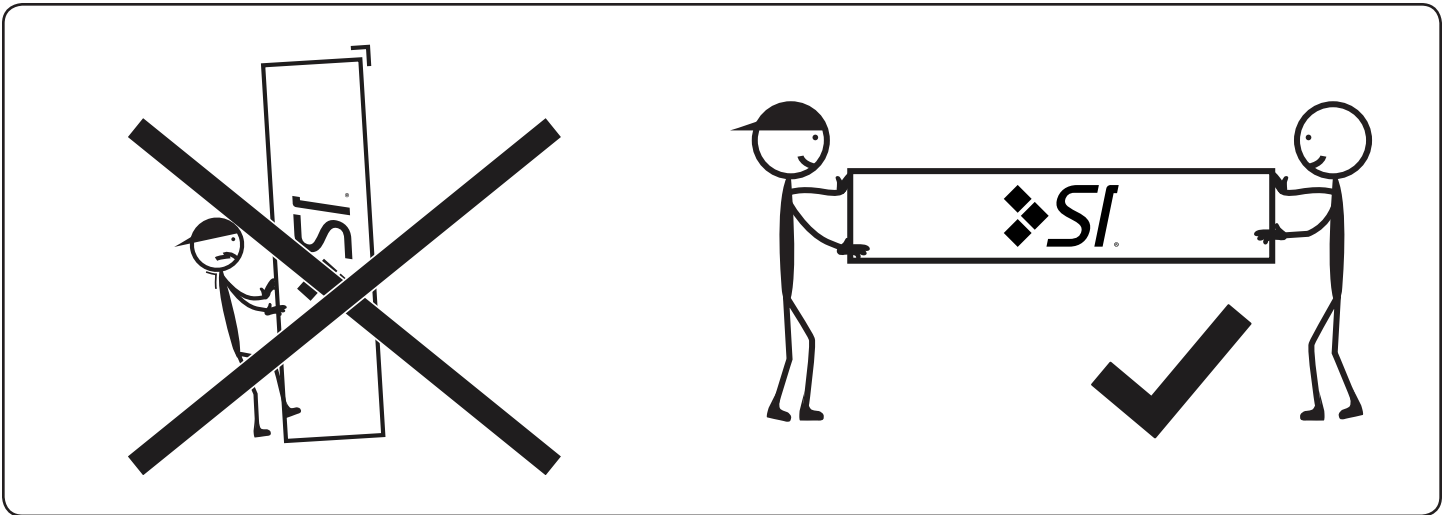

512-832-6939

9715-B Burnet Road Suite 400, Austin, TX 78758

SCREENINNOVATIONS.COM

5 SERIES ZERO EDGE Projector Placement

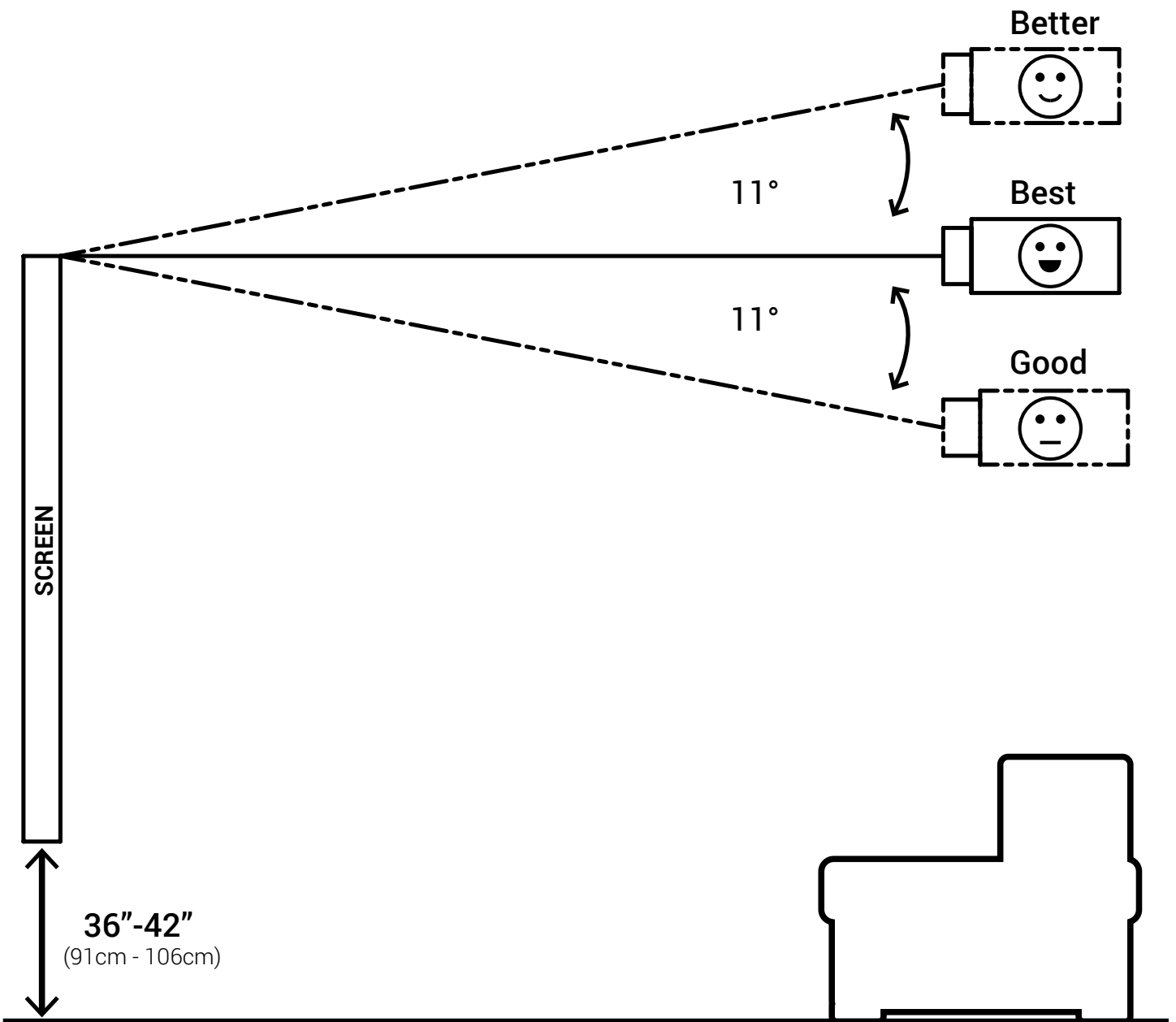

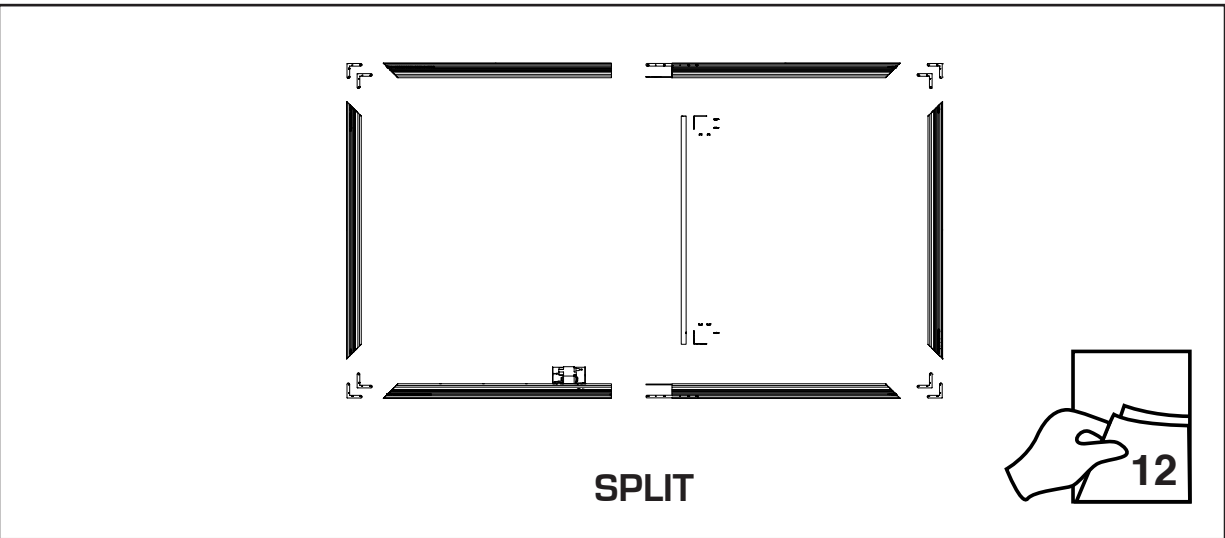
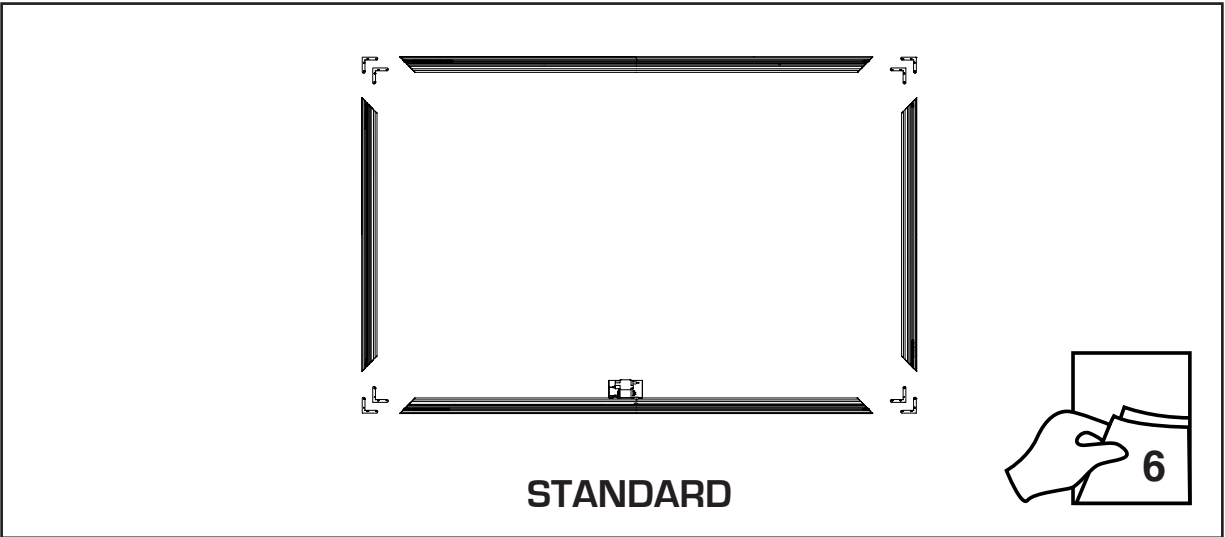
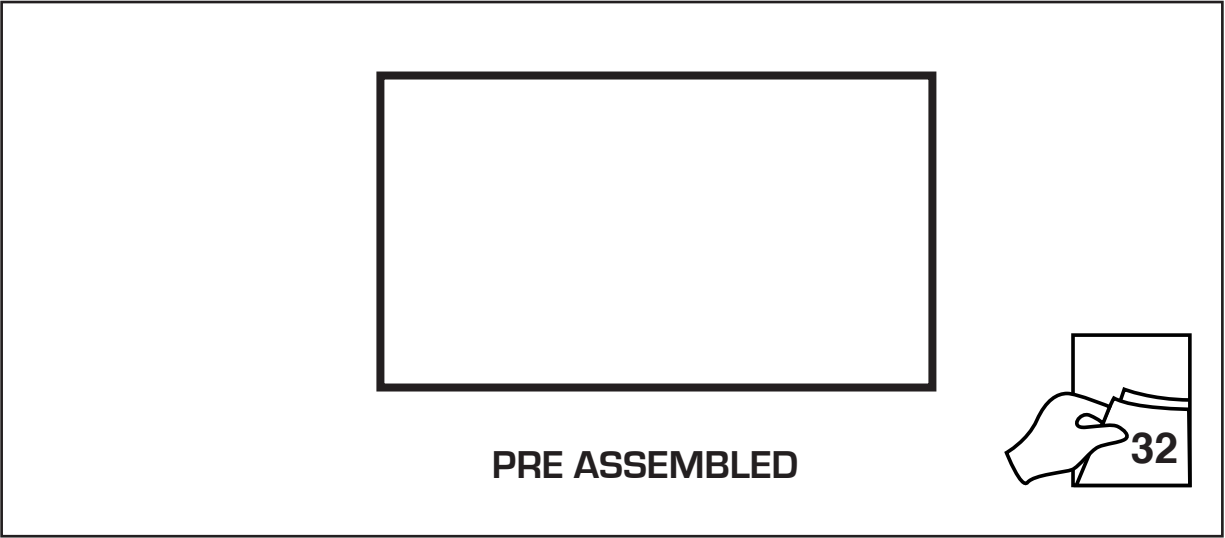

Frame Installation

(LED Lights Only)

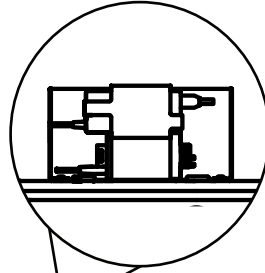
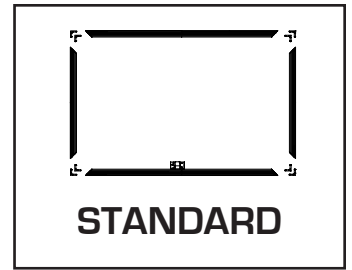

1X



1X



2X



2X

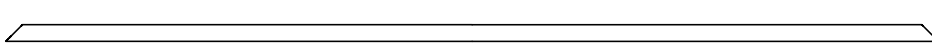

2X

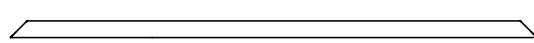

1X

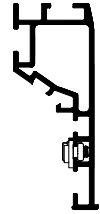
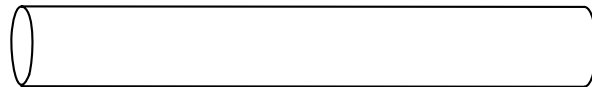

Hardware Kit

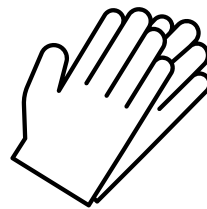
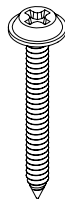
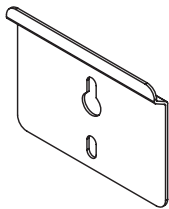

2X

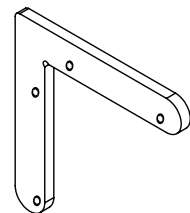

8X

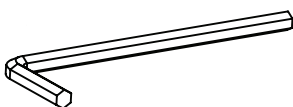

2X

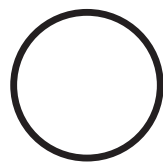

(MAESTRO ONLY)

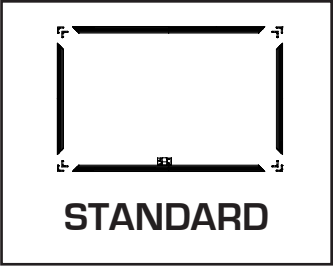

Flying Mount (Only)

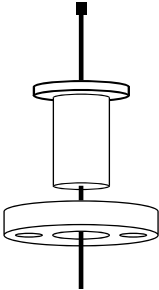

2X

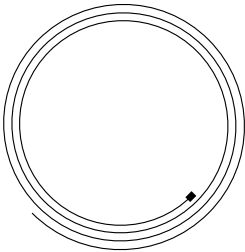

2X

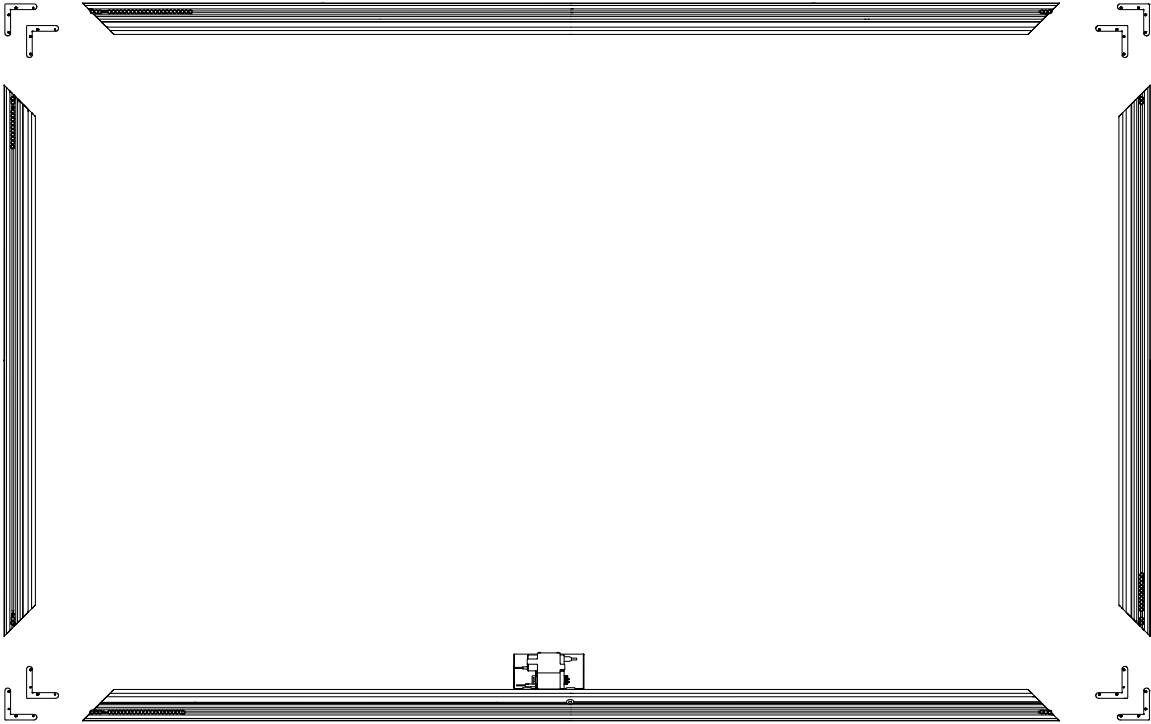

1

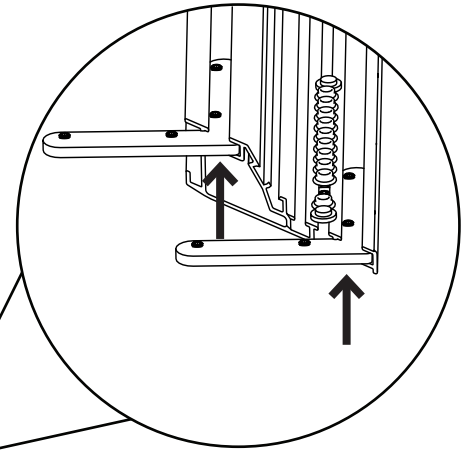
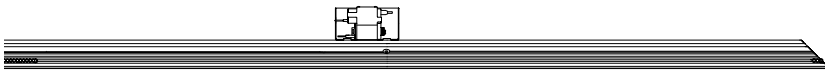
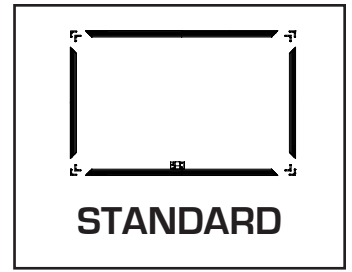

2

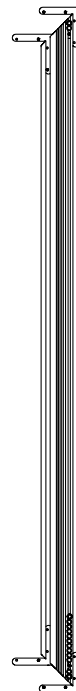
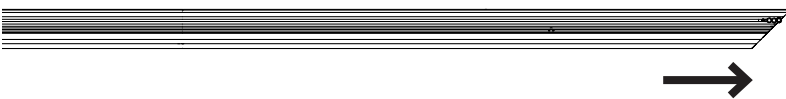

3

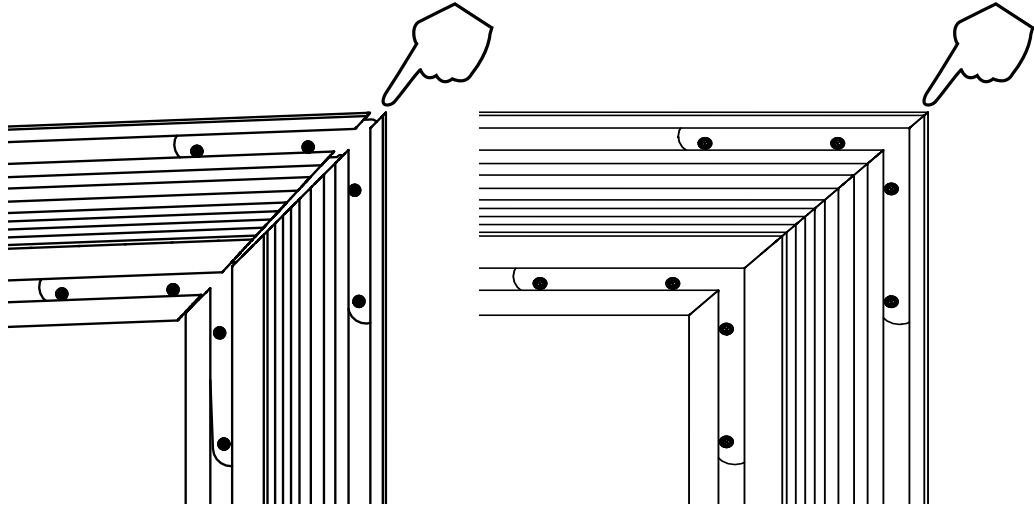
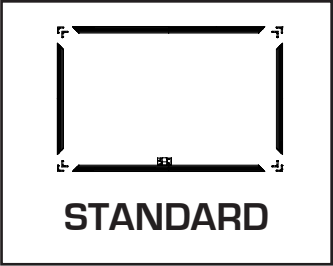

4

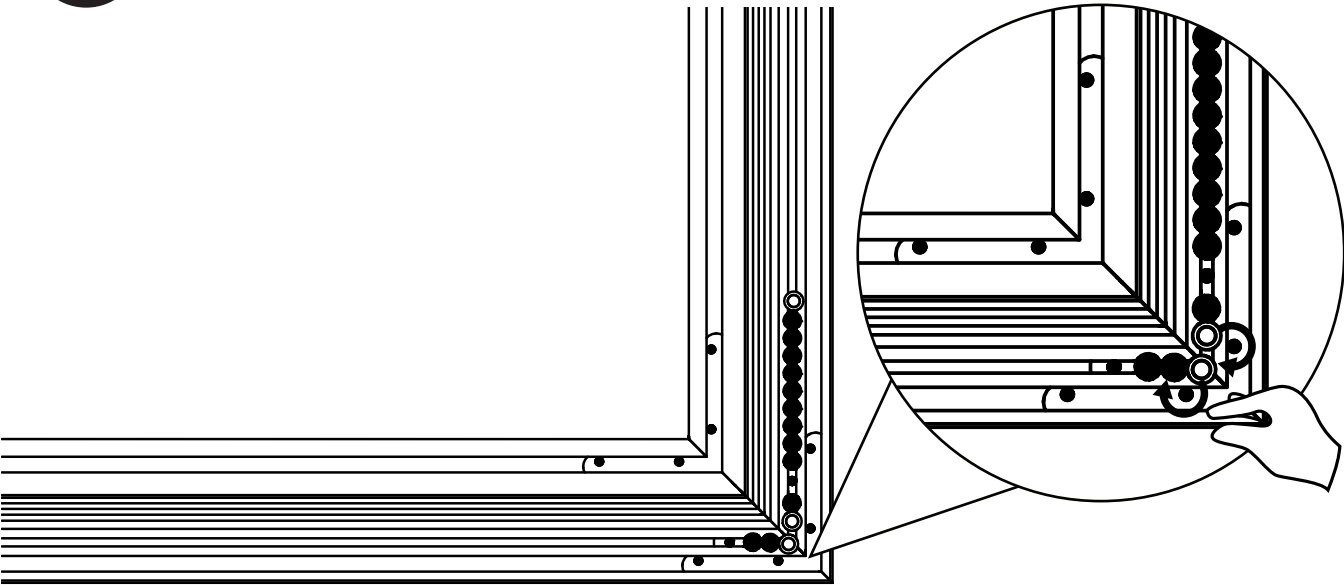

5

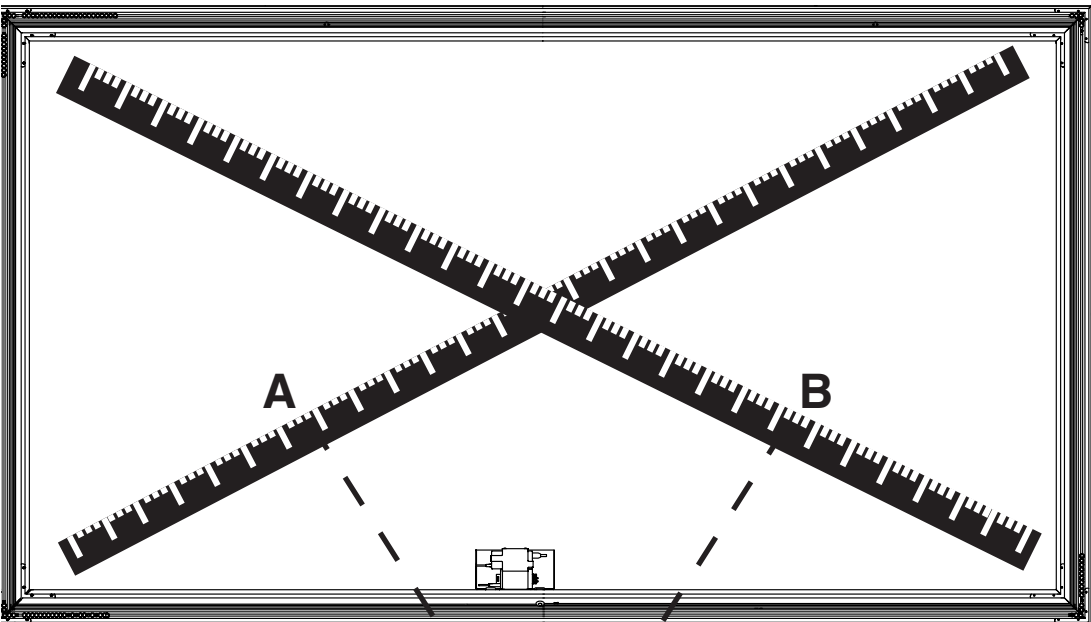
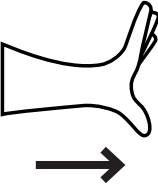
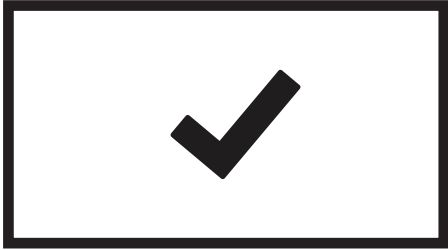
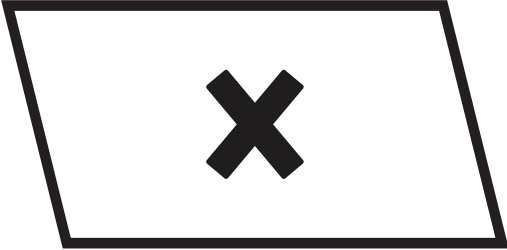
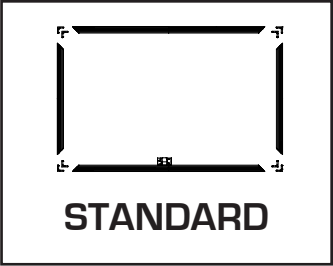

$A = B$

6

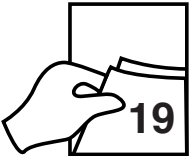
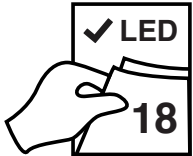
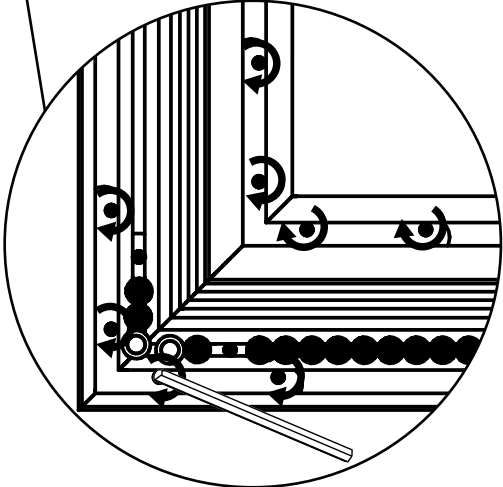

Frame Installation

(LED Lights Only)

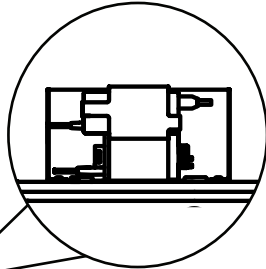
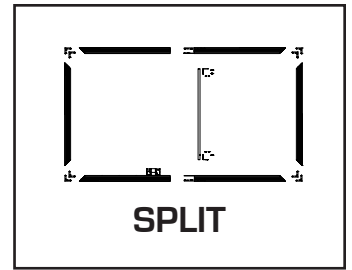

- 1X
- 1X
- 2X
- 2X
- 2X
- 1X
- 1X

Hardware Kit

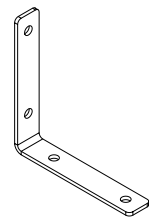
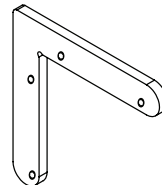
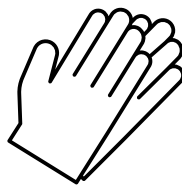
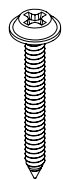
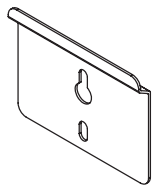

2X

8X

2X

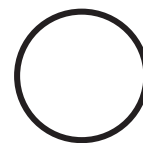
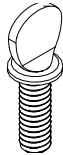

4X

4X

2X

(MAESTRO ONLY)

Flying Mount (Only)

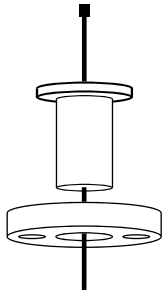

2X

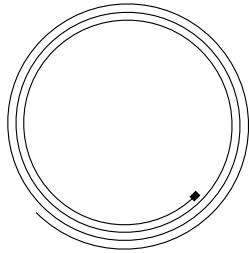

2X

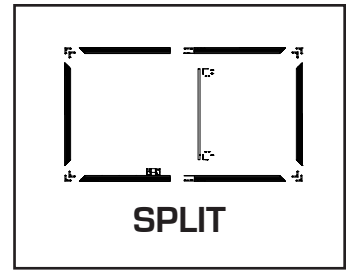

SPLIT

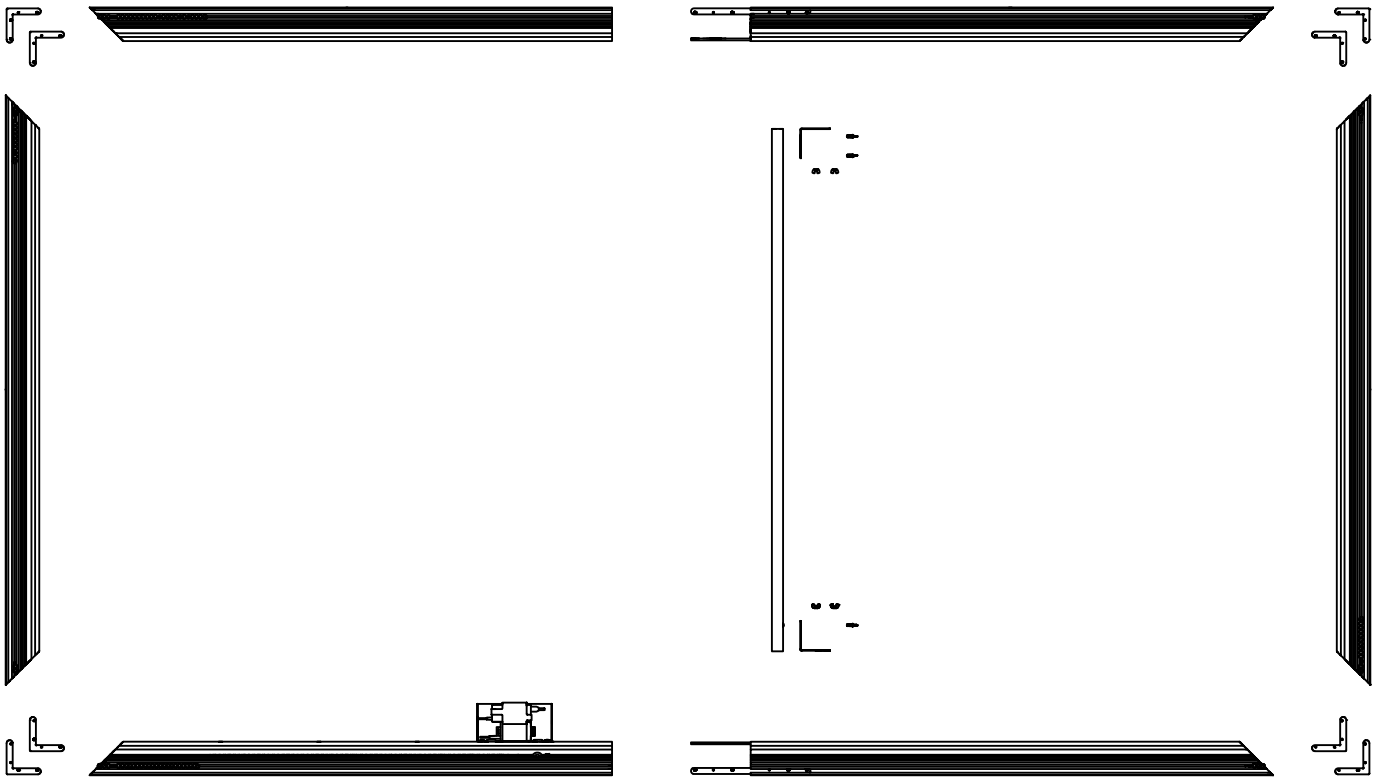

1

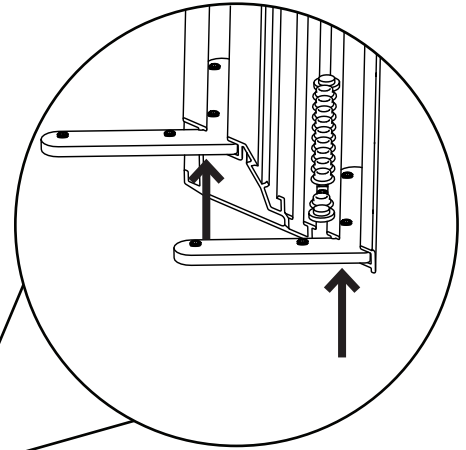
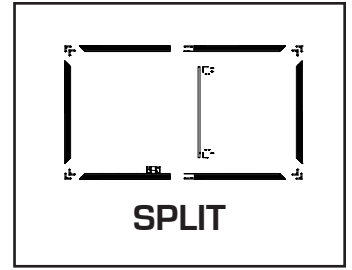

2



3

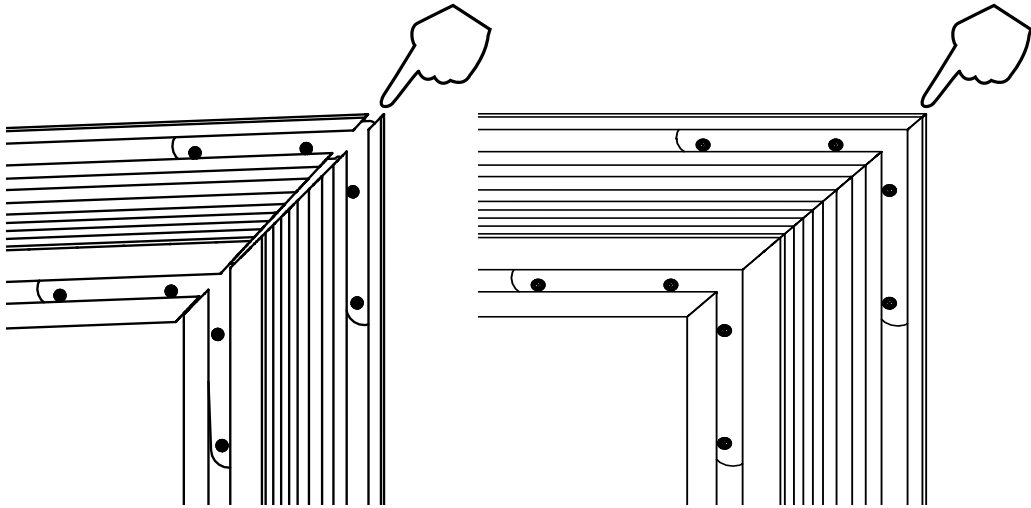
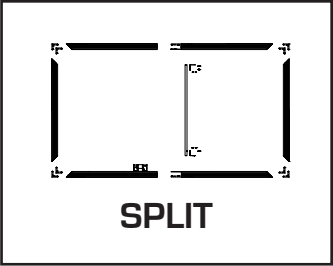

4

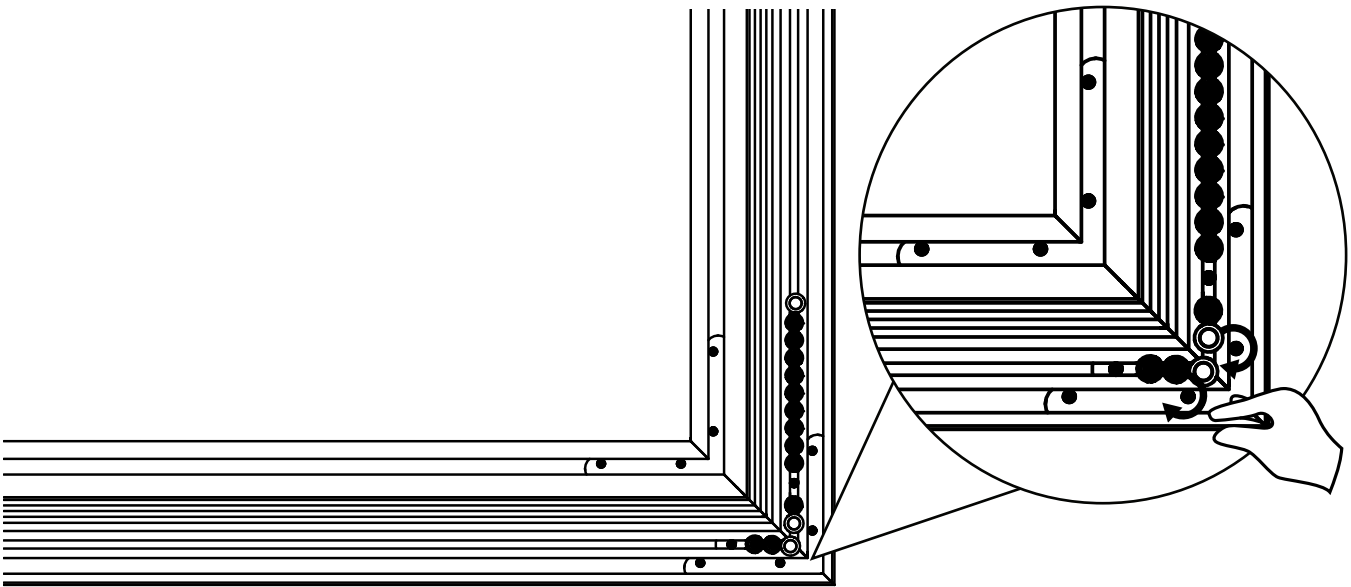

5

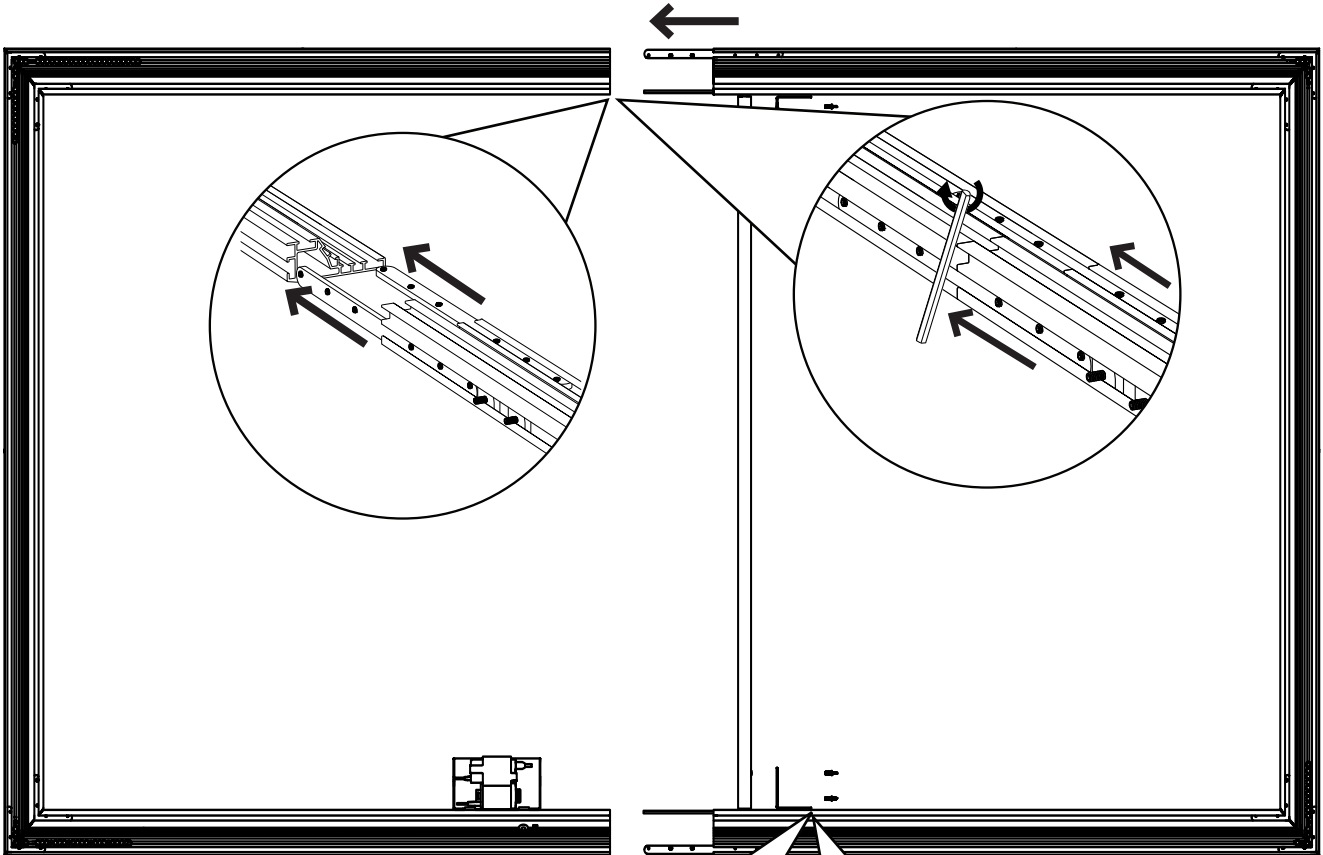
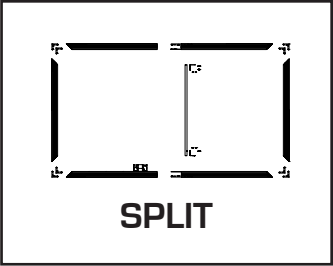

6

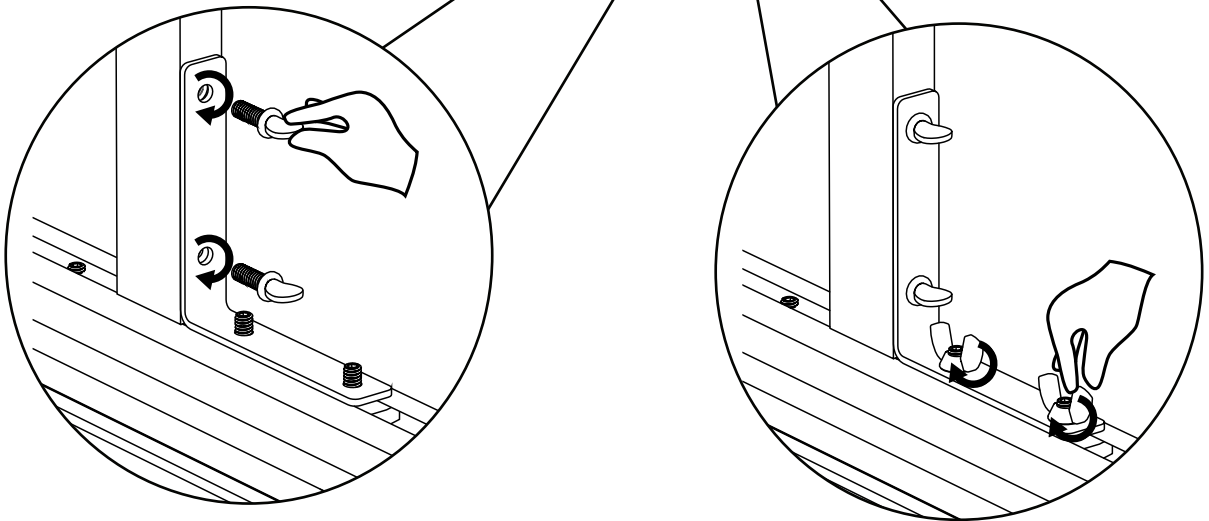

7

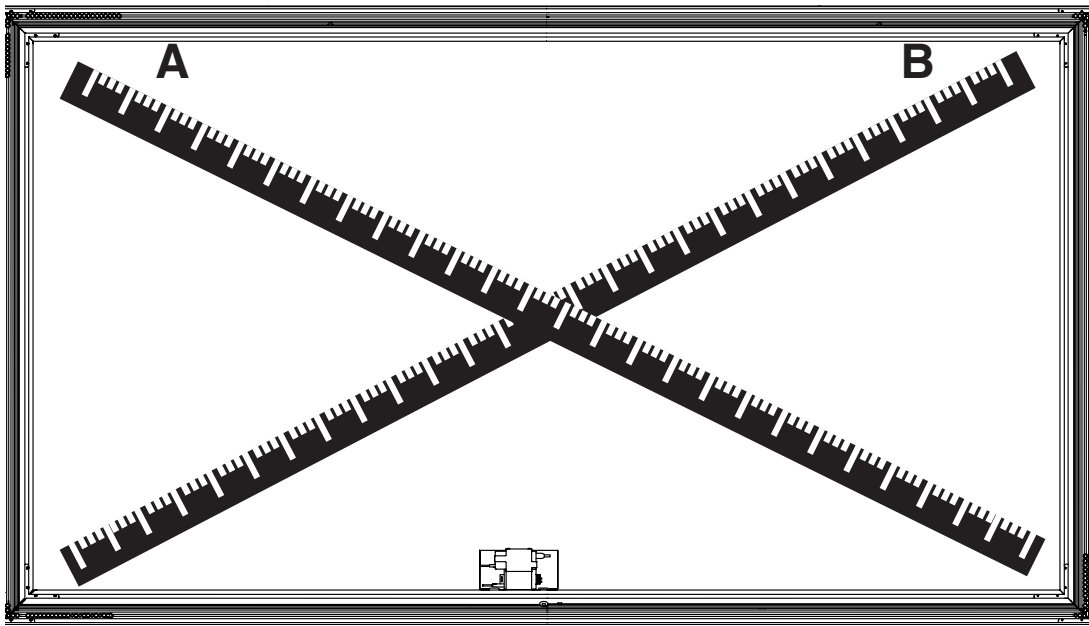
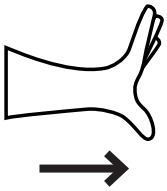
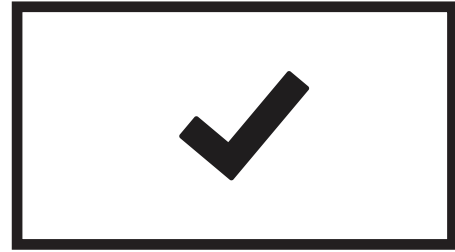
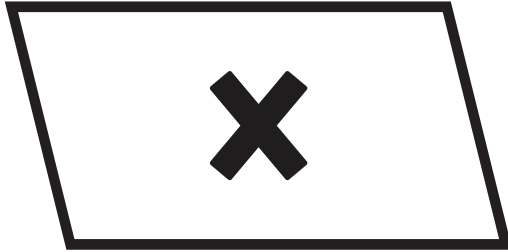
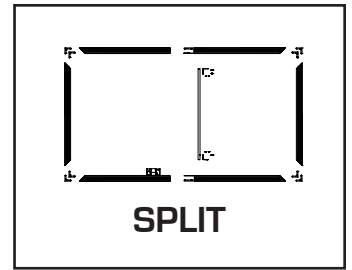

$A = B$

8

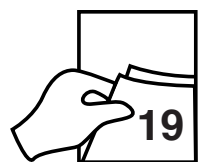
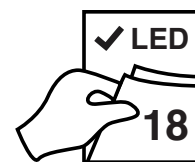
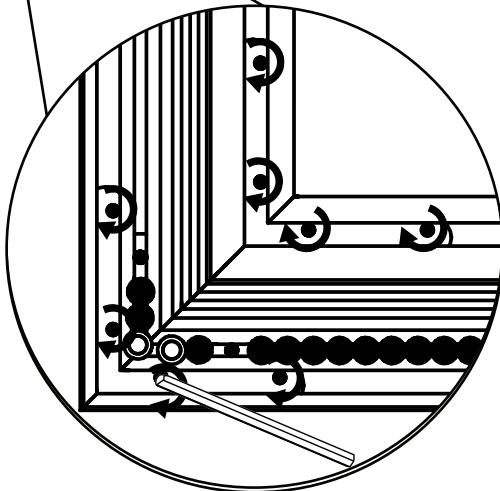

LED Lights

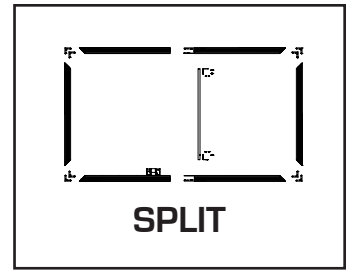

1

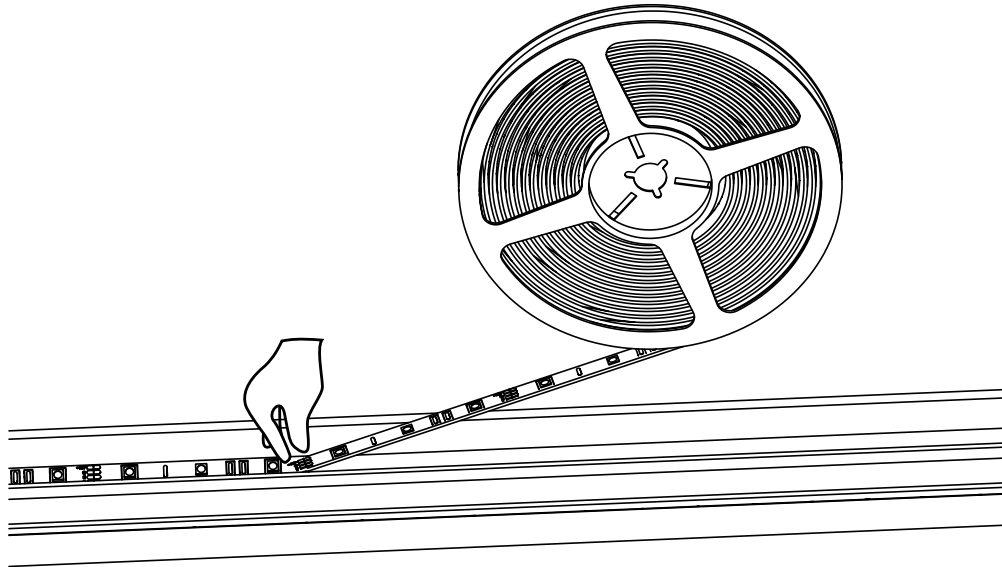

2

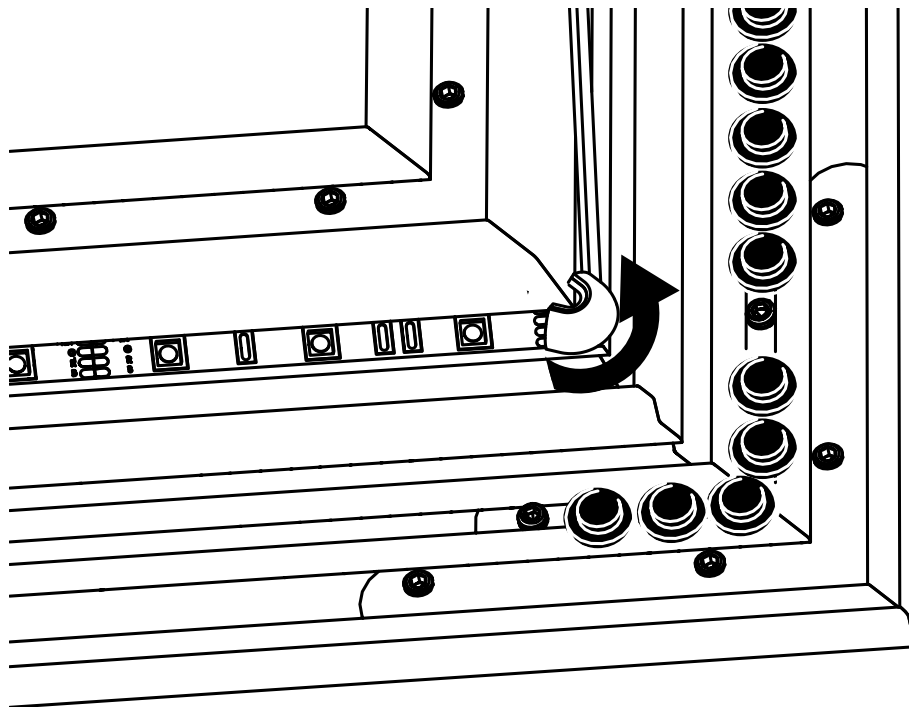

Material?

SLATE & PURE

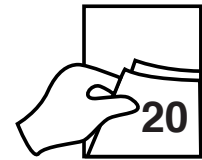

MAESTRO



1

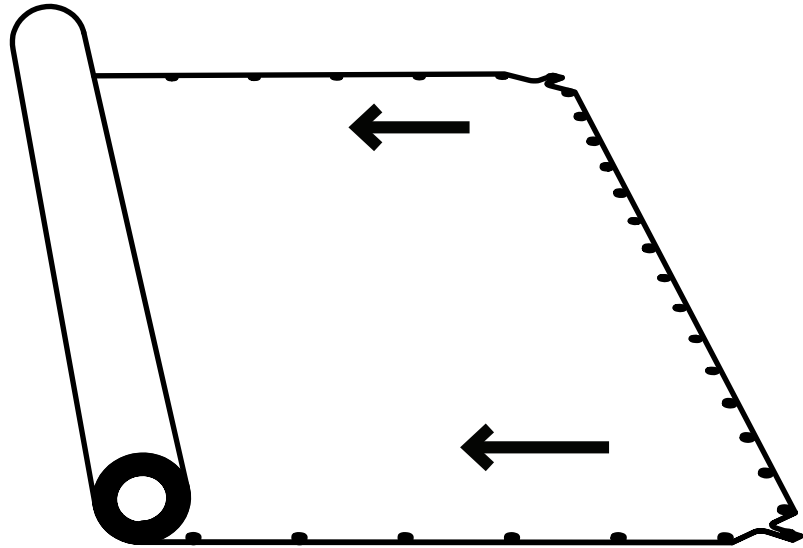
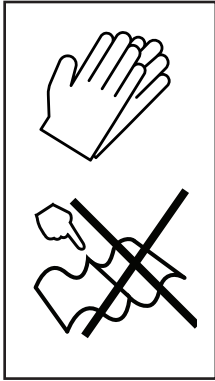

2

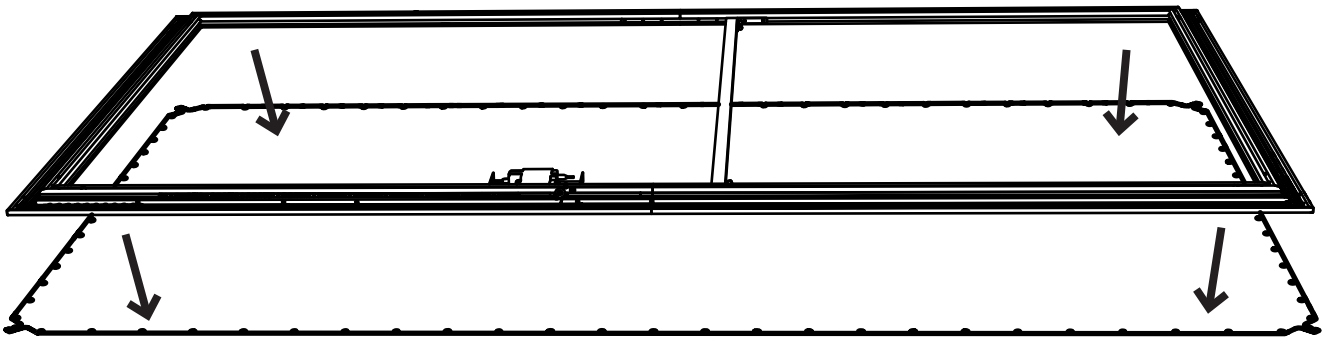

3

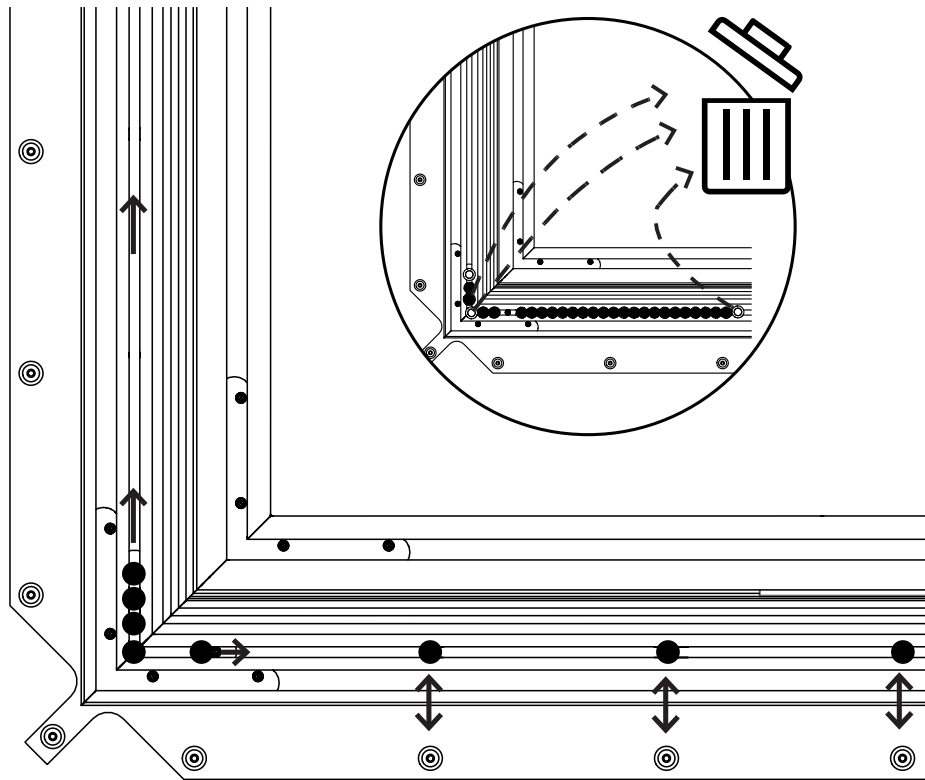

4

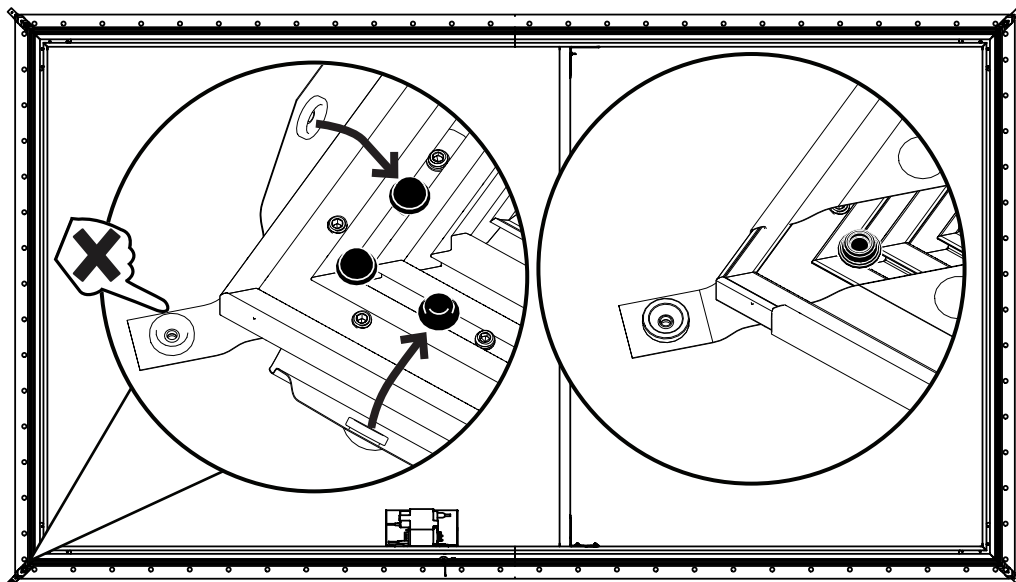

5

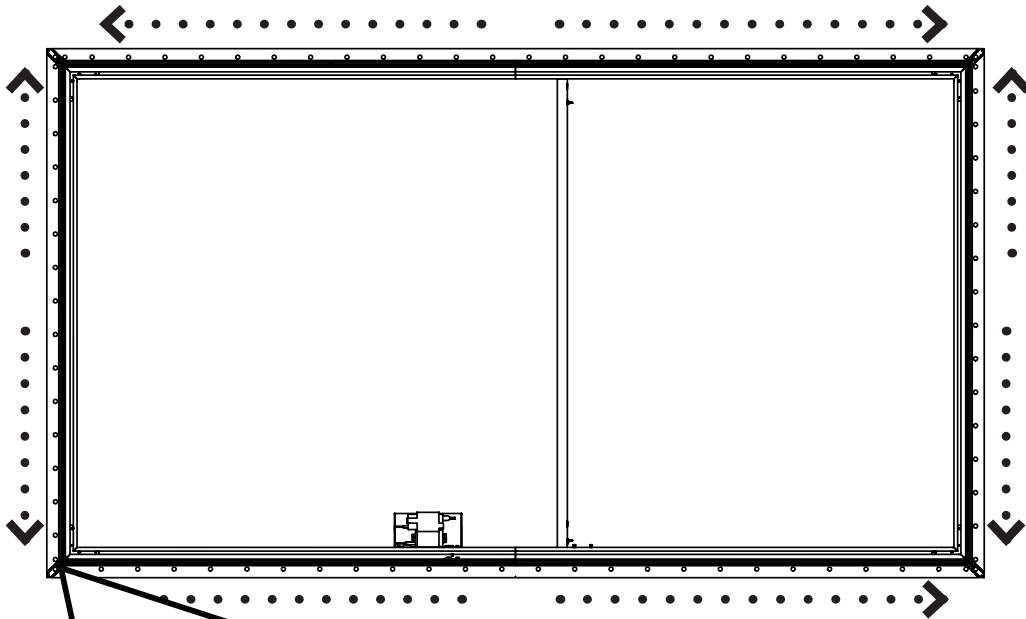

6

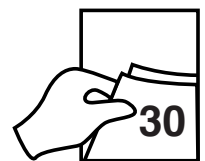
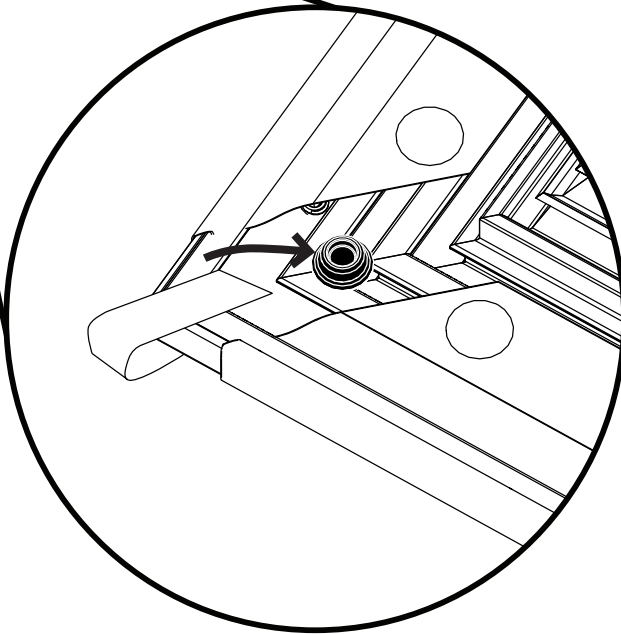

Material Installation

1

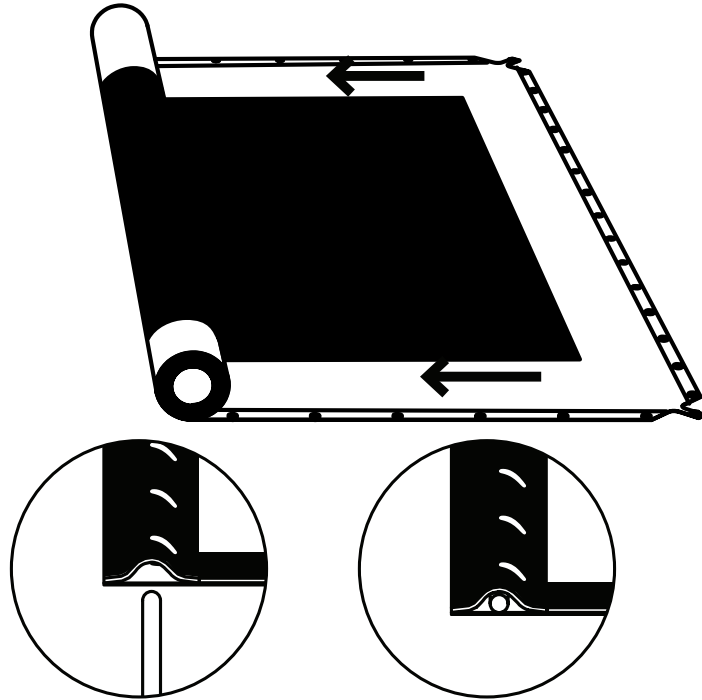
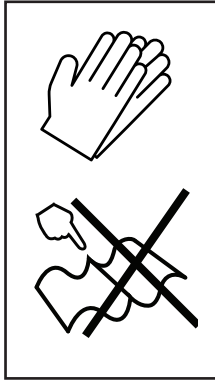

2

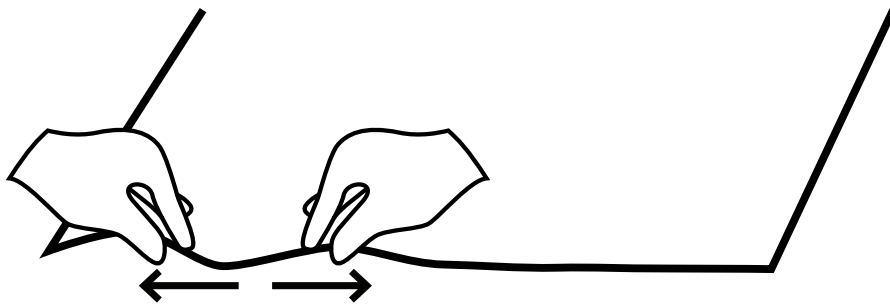

3

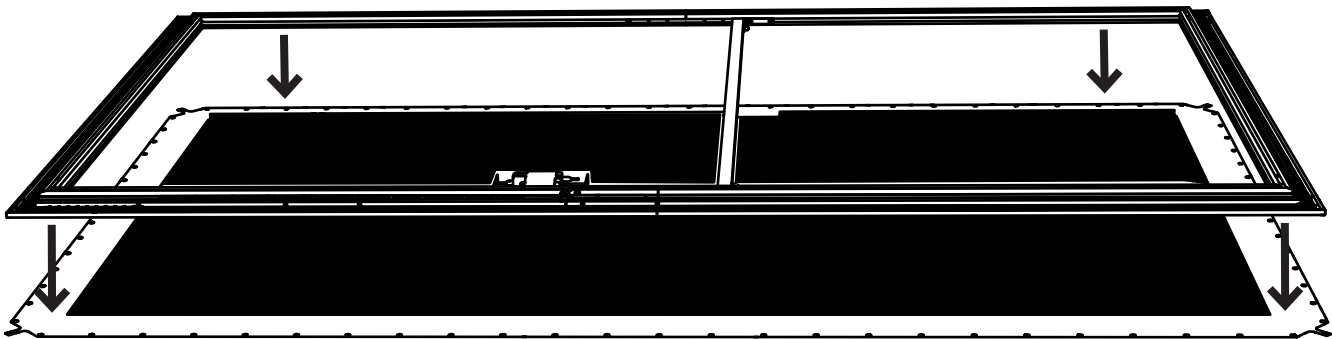

4

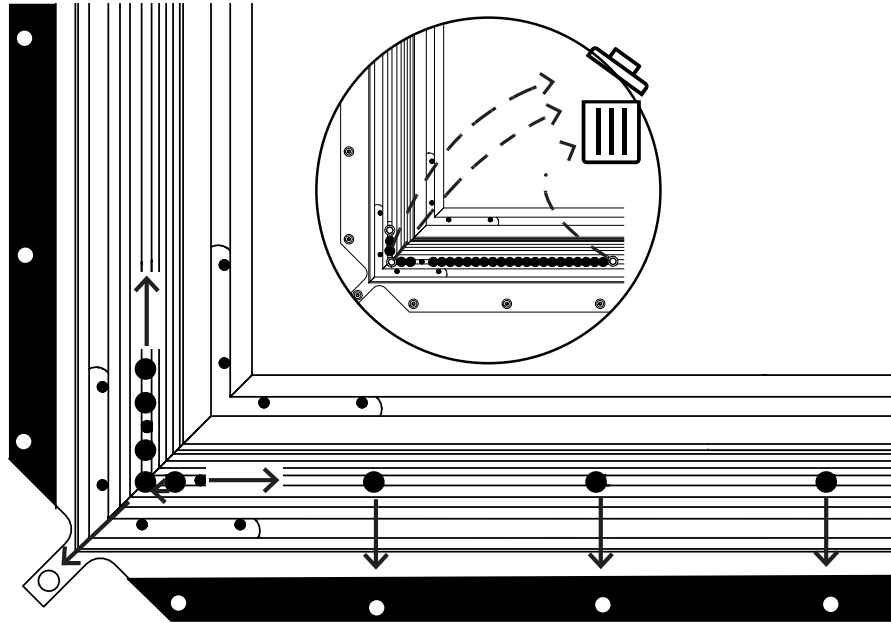

5

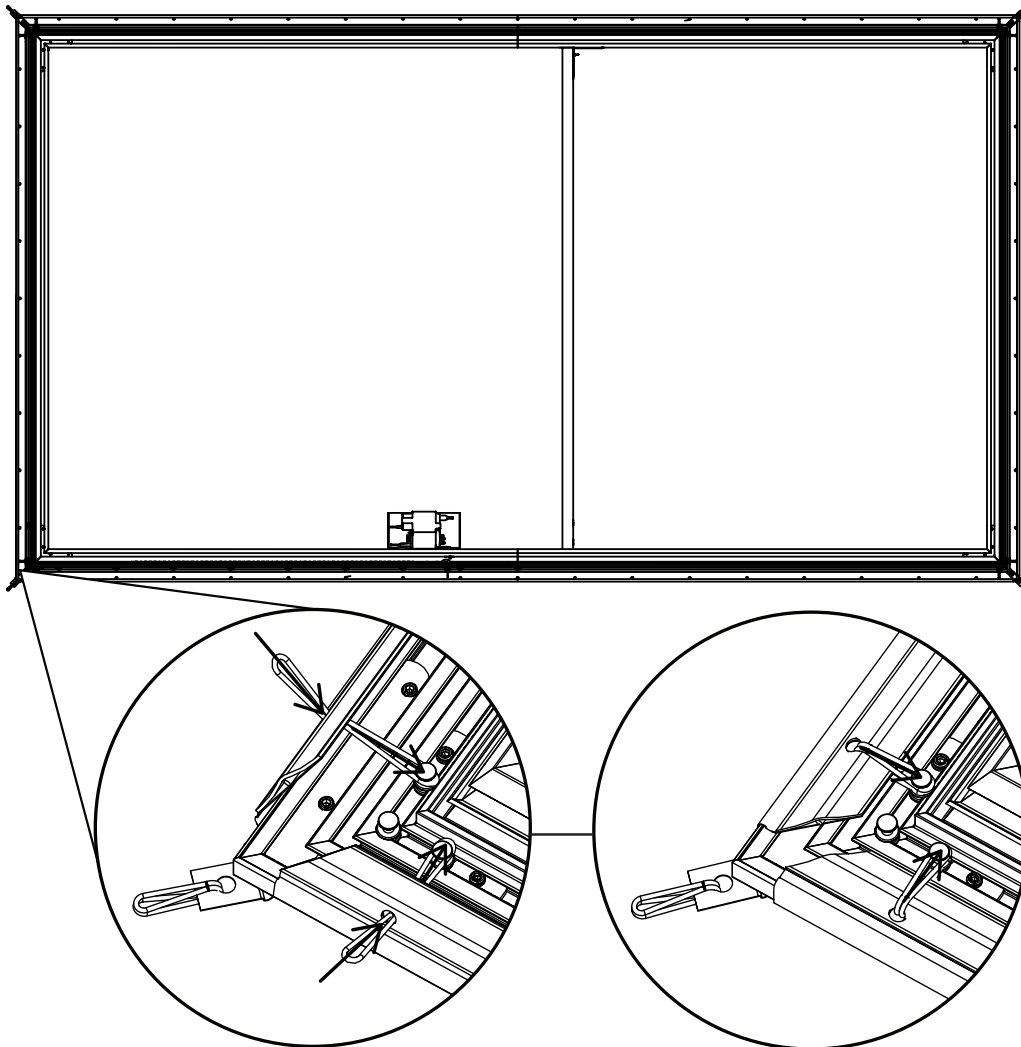

6

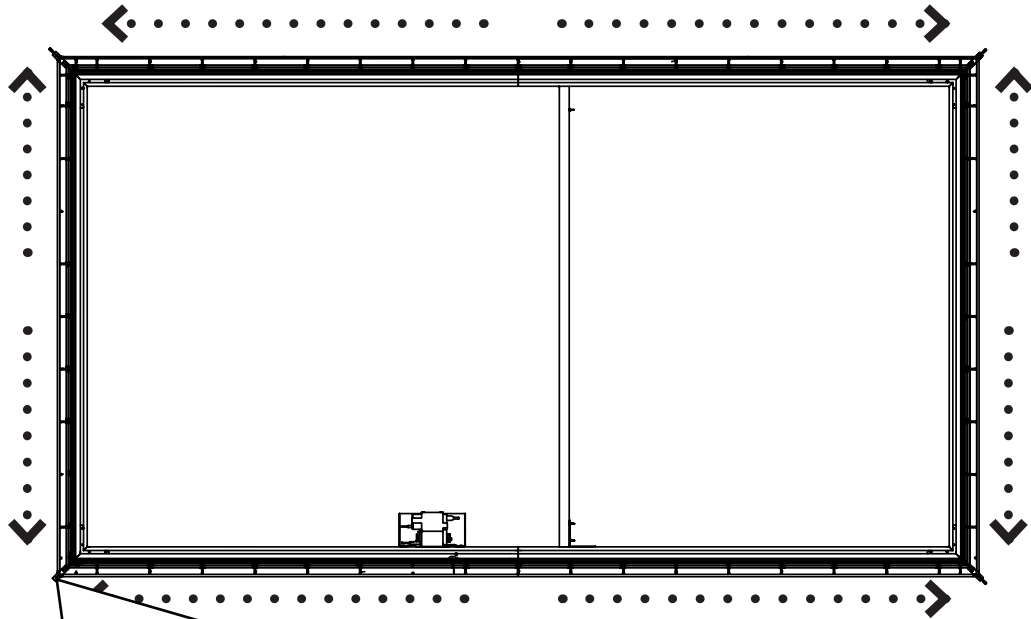

7

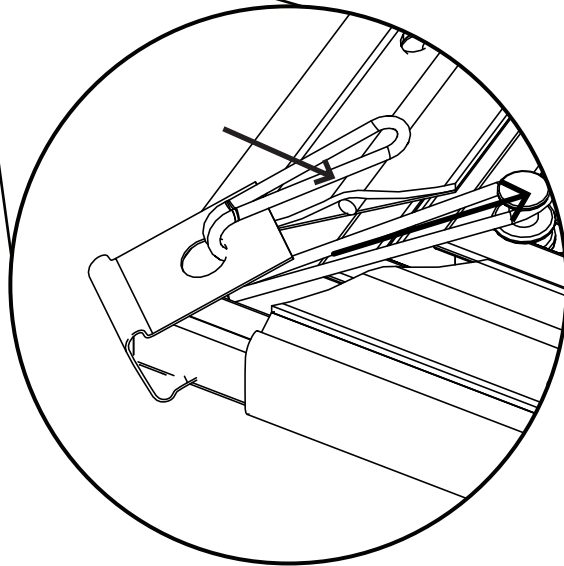

8

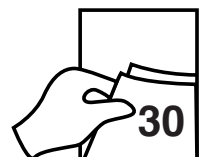
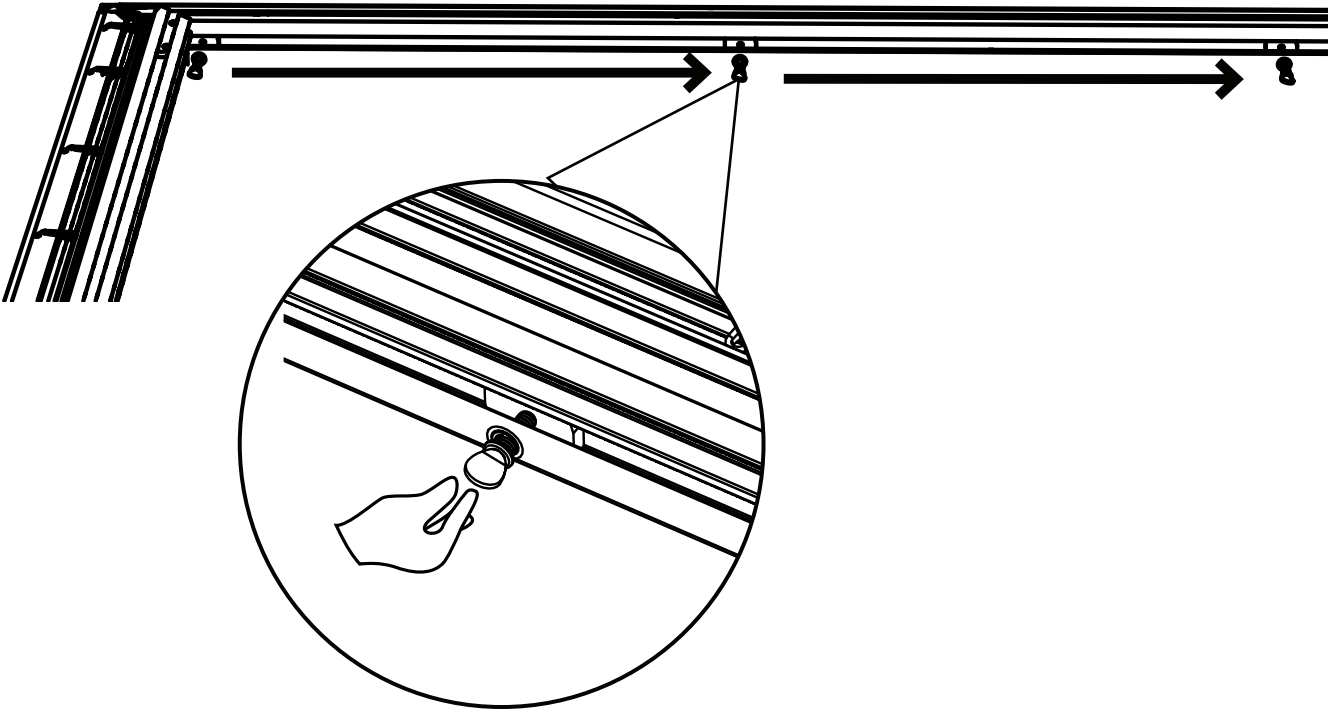

5 SERIES ZERO EDGE

Trim Installation

1

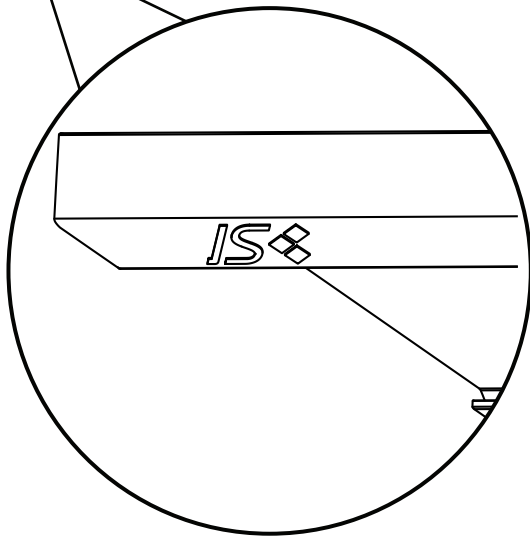
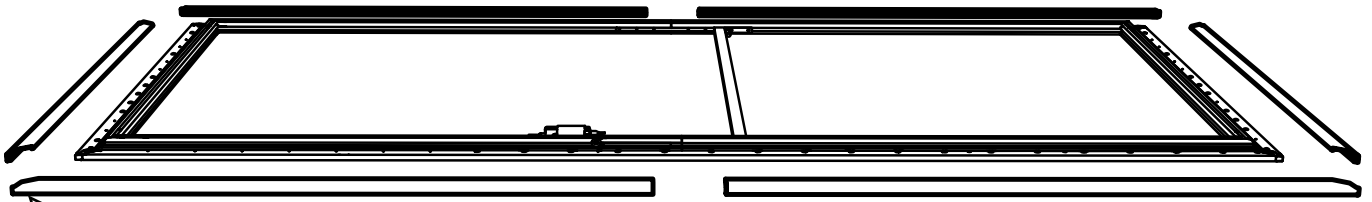

2

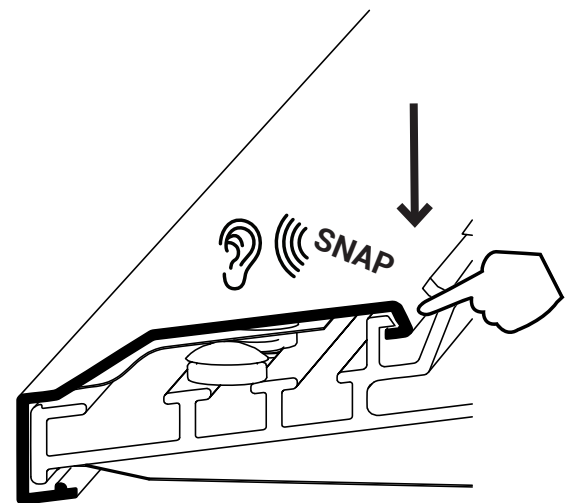
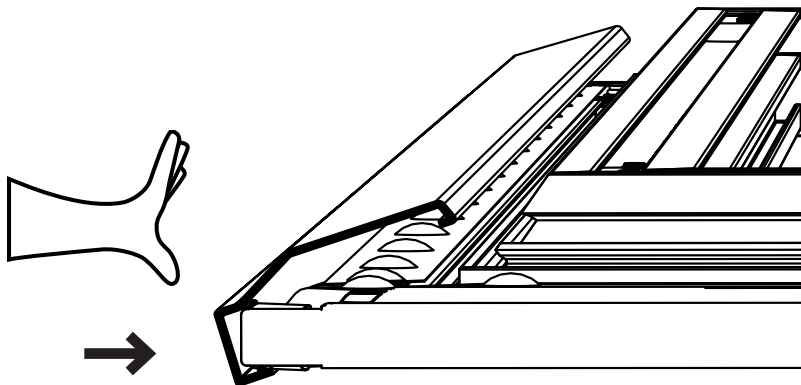

5 SERIES ZERO EDGE Screen Mounting

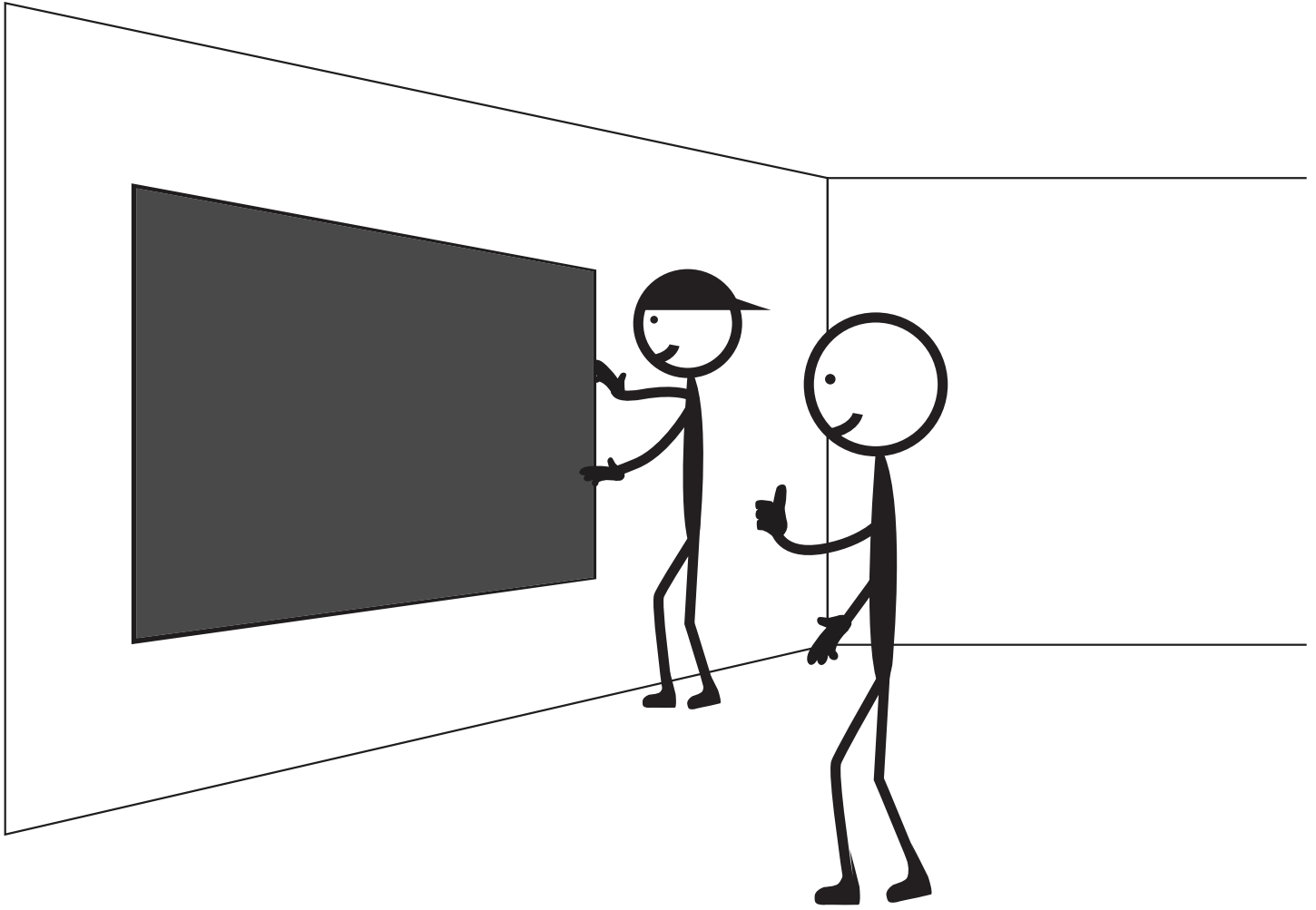

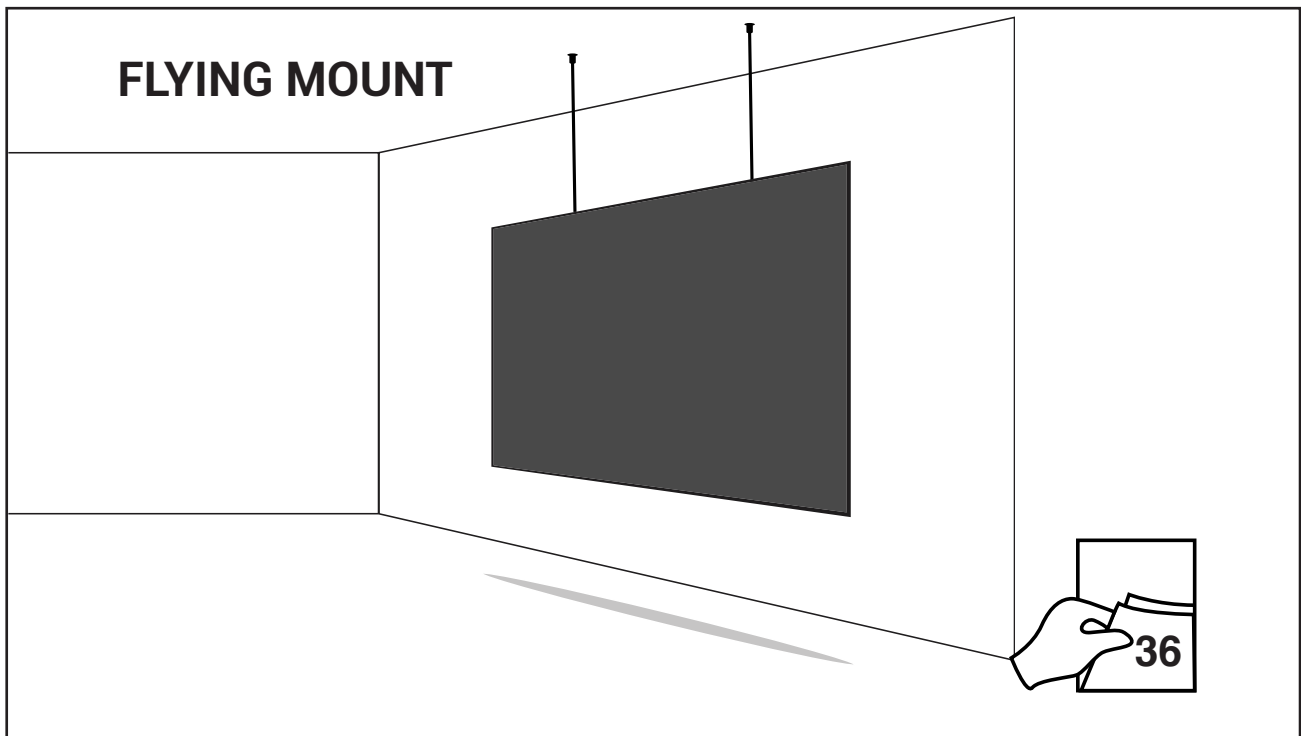
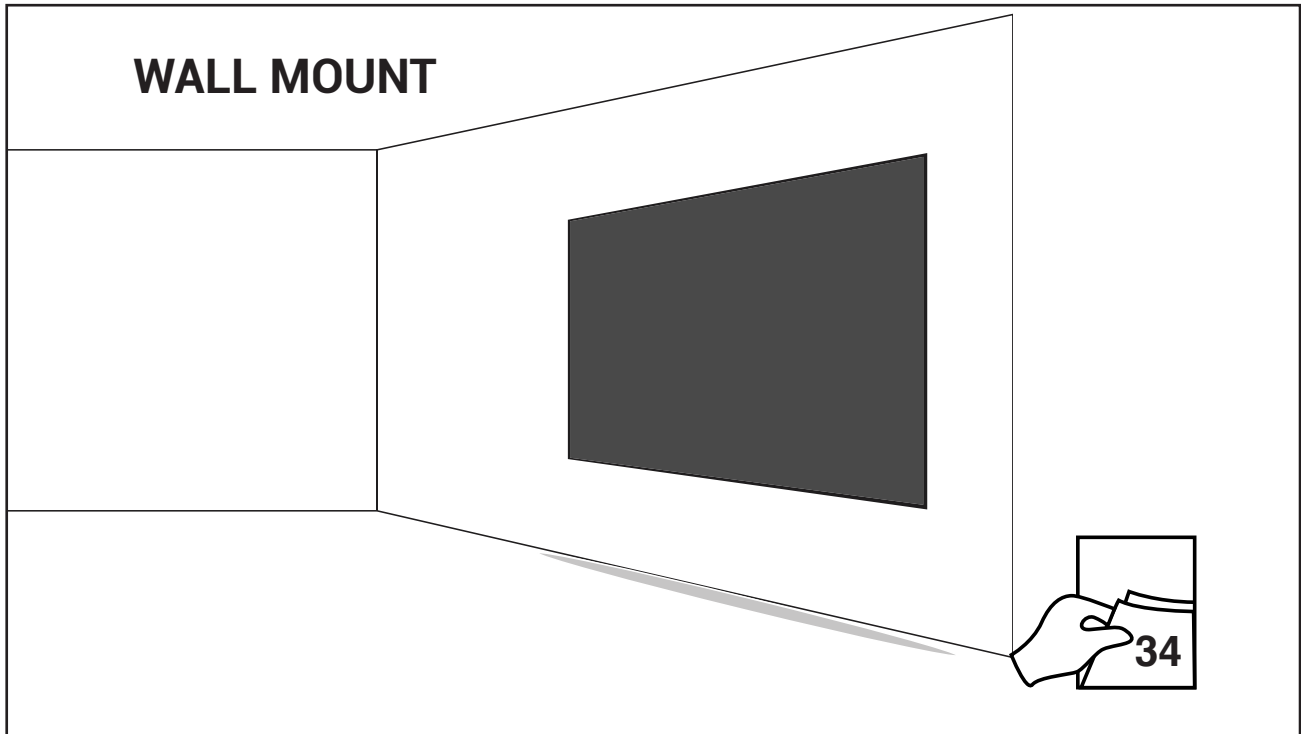

1

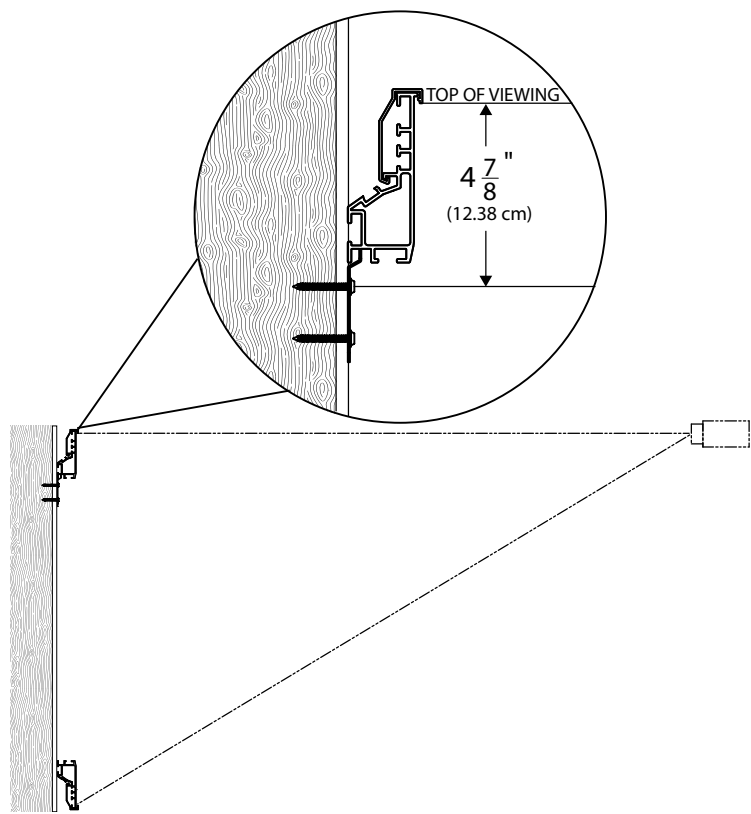
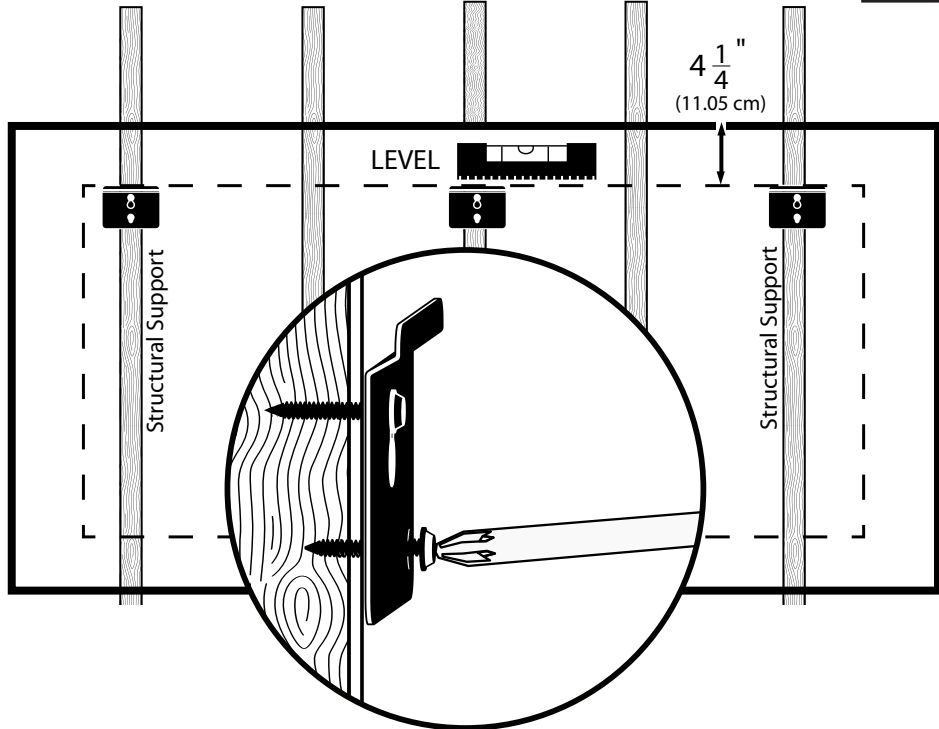
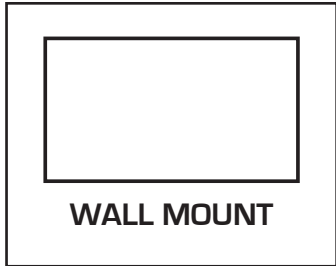

2

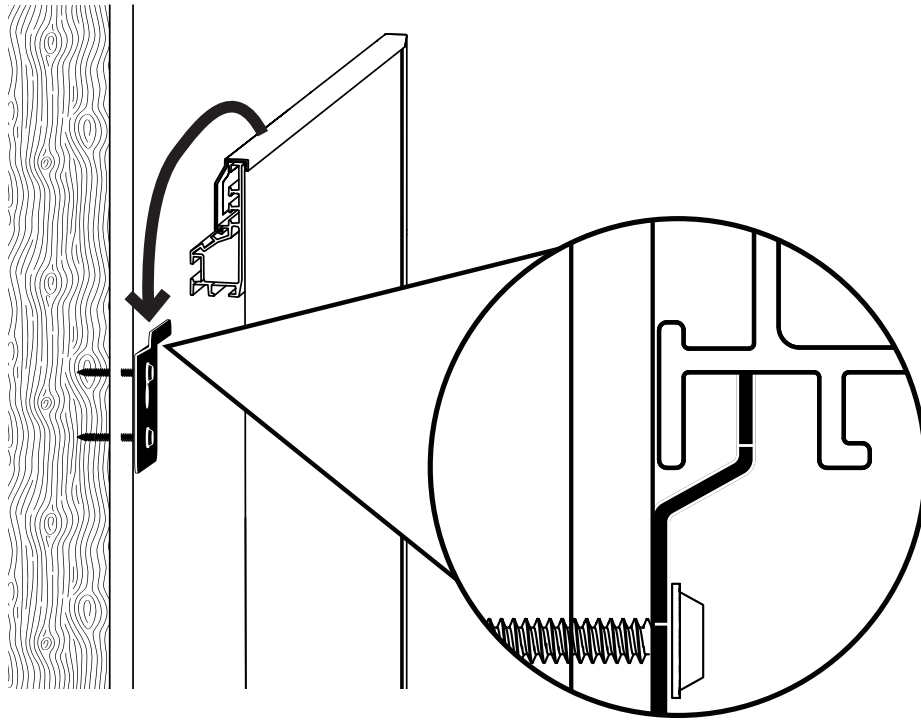
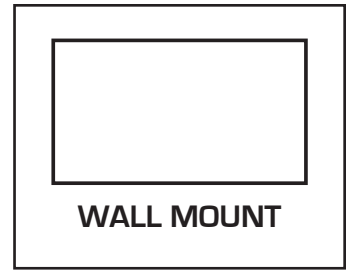

3

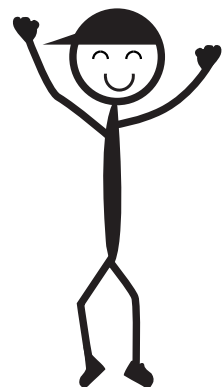
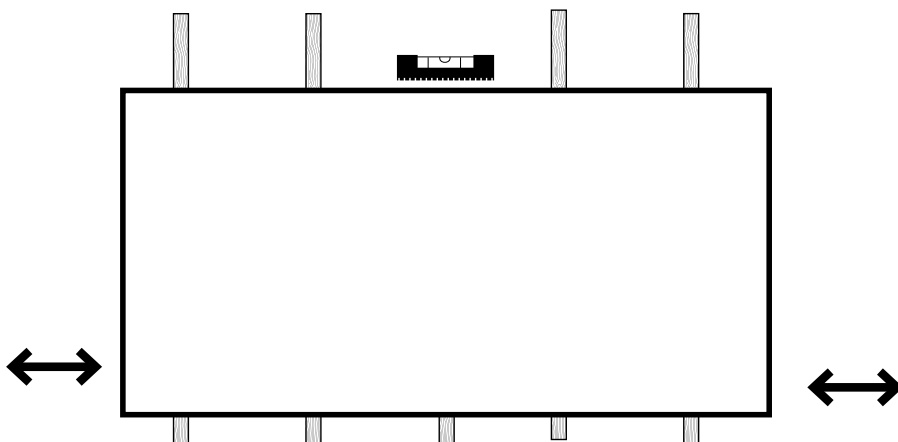

1

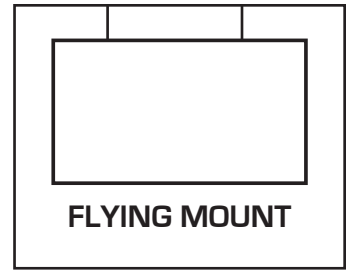
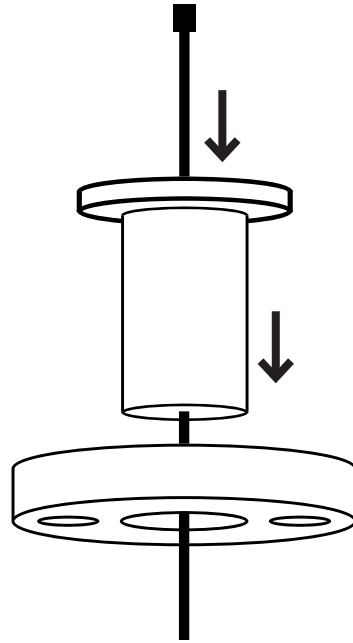

2

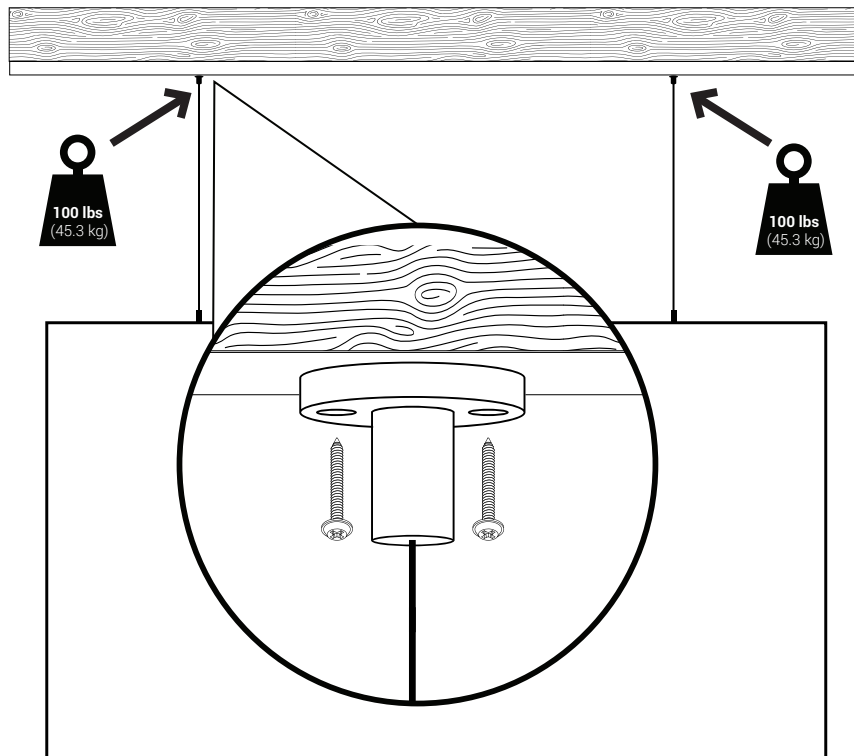

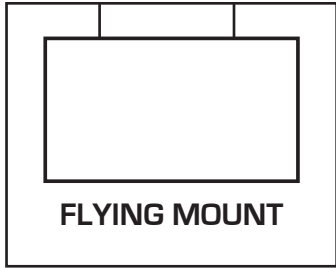

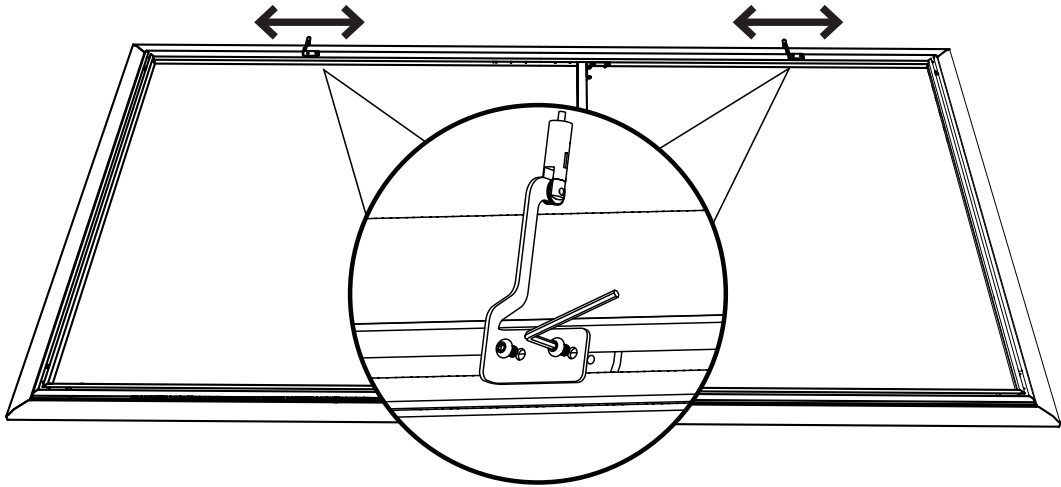

3

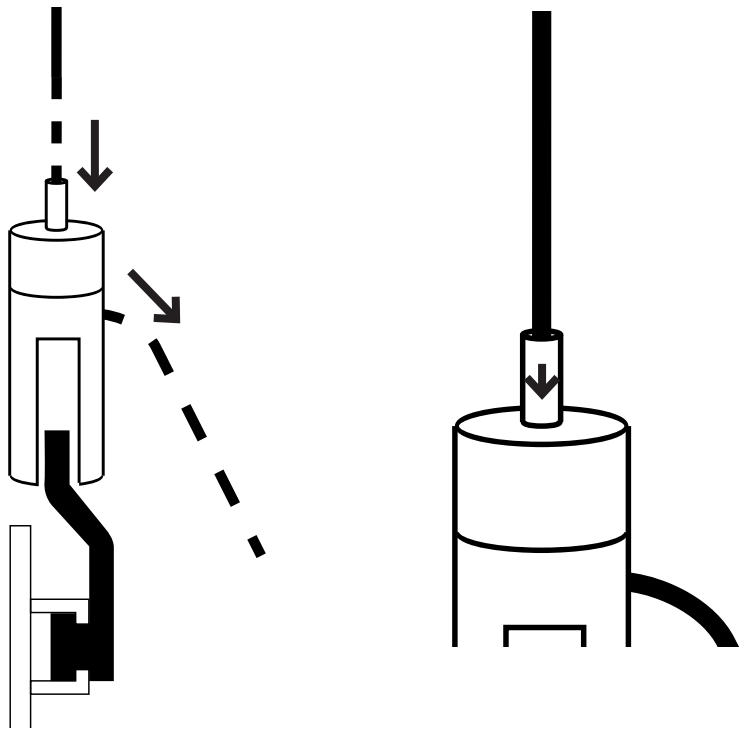

4



NOTE: If you pull too far the screen can be lowered by pushing down the button on the top of the flying mount.

 We recommend you don't cut the extra cables for future adjustability. Simply tape the extra cable to the back of the screen frame.

LED Lighting Hex Codes

2013 5CA3	2013 5DA2	2013 41BE	2013 40BF
2013 58A7	2013 59A6	2013 45BA	2013 44BB
2013 54AB	2013 55AA	2013 49B6	2013 48B7
2013 50AF	2013 51AE	2013 4DB2	2013 4CB3
2013 1CE3	2013 1DE2	2013 1EE1	2013 1FE0
2013 18E7	2013 19E6	2013 1AE5	2013 1BE4
2013 14EB	2013 15EA	2013 16E9	2013 17E8
2013 10EF	2013 11EE	2013 12ED	2013 13EC
2013 0CF3	2013 0DF2	2013 0EF1	2013 0FF0
2013 08F7	2013 09F6	2013 0AF5	2013 0BF4
2013 04FB	2013 05FA	2013 06F9	2013 07F8

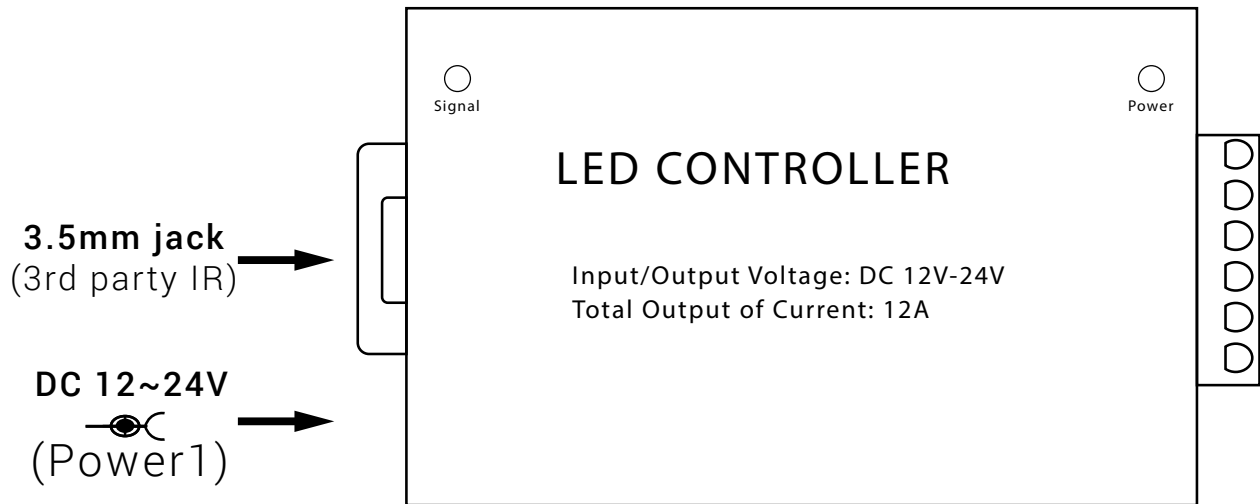



LIFETIME REPLACEMENT POLICY

Thank you for purchasing a genuine Screen Innovations product! We are **100%** committed to your satisfaction and welcome your feedback. Please retain this page for your records.

New SI products carry a standard 1-year parts and labor warranty. Older products are covered by our Lifetime Replacement policy.

To activate your Lifetime Replacement Policy, simply “Like” us on Facebook and/or “Follow” us on Twitter, and by all means, tell us about your SI experience! If you do not use Facebook or Twitter, you can submit your information online:

www.screeninnovations.com/forms/lifetime-replacement-policy/



NOTES:

9715-B Burnet Road Suite 400, Austin, TX 78758

Tel: 512-832-6939 Fax: 512-832-6136

www.screeninnovations.com



NOTES:

9715-B Burnet Road Suite 400, Austin, TX 78758

Tel: 512-832-6939 Fax: 512-832-6136

www.screeninnovations.com



NOTES:

9715-B Burnet Road Suite 400, Austin, TX 78758

Tel: 512-832-6939 Fax: 512-832-6136

www.screeninnovations.com

